



Simplifying and Systematizing Science at Unprecedented Scales & Complexity

Michael S. Noble
Genome Data Analysis Center
The Broad Institute of MIT & Harvard

Cancer Genome Summit

December 6, 2012

Boston, Massachusetts, USA



Acknowledgements

PI: Lynda Chin, Gaddy Getz

Broad Institute

Michael S. Noble

Douglas Voet

Daniel DiCara

Gordon Saksena

Hailei Zhang

David Heiman

Juok Cho

William Mallard

Michael Lawrence

Petar Stojanov

Lihua Zou

Chip Stewart

Scott Frazer

Pei Lin

Kristian Cibulskis

Rui Jing

Jaegil Kim

Lee Lichtenstein

Aaron McKenna

Andrey Sivachenko

Carrie Sougnez

Lee Lichtenstein

Steven Schumacher

Raktim Sinha

Belfer/DFCI/MDACC

Juinhua Zhang

Spring Liu

Sachet Shukla

Terrence Wu

IGV & GenePattern teams @ Broad

Jill Mesirov

Michael Reich

Peter Carr

Marc-Danie Nazaire

Jim Robinson

Helga Thorvaldsdottir

Broad Institute Leadership: Todd Golub, Eric Lander

Harvard Medical School

Matthew Meyerson

Scott Carter

Juliann Chmielecki

Andrew Cherniack

Rameen Beroukhim

Peter Park

Nils Gehlenborg

Semin Lee

Richard Park

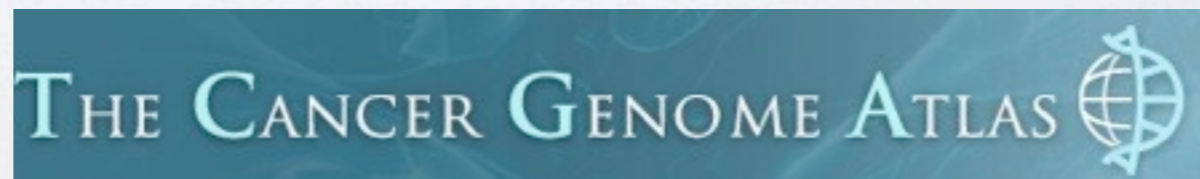

OUTLINE

- I. Why Firehose
- II. TCGA Data Flow
- III. What Firehose produces
- IV. How To Get It

I. WHY FIREHOSE?

Born of the desire to systematize analyses from The Cancer Genome Atlas pilot and scale their execution to the dozens of remaining diseases to be studied, now sits atop ~35 terabytes of TCGA data and reliably executes more than 2300 pipelines per month.



Because The Bad Old Days ...

Because The Bad Old Days ...

Of solitary, manual experimentation on few dozen samples ...

```
% create a folder
```

```
% download data.from.some.where
```

```
% run_your_computational_analysis
```

Because The Bad Old Days ...

Of solitary, manual experimentation on few dozen samples ...

```
% create a folder
```

```
% download data.from.some.where
```

```
% run_your_computational_analysis
```

Then do it again Nov 13, 17, ...

Then forget, search ... lose track, search ...

Then repeat ALL for 20 more tumors

GBM, LUNG, AML, ...

Because The Bad Old Days ...

Of solitary, manual experimentation on few dozen samples ...

```
% create a folder
```

```
% download data.from.some.where
```

```
% run_your_computational_analysis
```

Then do it again Nov 13, 17, ...

Then forget, search ... lose track, search ...

Then repeat ALL for 20 more tumors

GBM, LUNG, AML, ...

Then multiply by 5, 10 ... researchers at your site

Don't Scale to TCGA

November 14, 2012
Firehose Data Snapshot

Tumor	BCR	Clinical	CN	LowP	Methylation	mRNA	mRNAseq	miR	miRseq	RPPA	MAF
BLCA	153	108	99	0	138	0	96	0	124	54	28
BRCA	914	866	874	0	889	529	805	0	868	408	507
CESC	122	32	102	0	122	0	0	0	122	0	36
COAD	423	423	413	69	420	155	192	0	407	269	155
COADREAD	592	591	575	104	582	224	264	0	550	399	224
DLBC	28	0	17	0	17	0	0	0	16	0	0
GBM	598	565	563	0	411	542	161	491	0	214	276
HNSC	328	315	294	96	310	0	303	0	309	212	0
KICH	66	0	65	0	65	0	0	0	0	0	0
KIRC	502	502	493	0	500	72	469	0	480	454	403
KIRP	149	103	103	0	103	16	63	0	103	0	0
LAML	202	200	0	0	194	0	179	0	187	0	199
LGG	222	198	180	0	176	27	110	0	180	0	0
LIHC	99	62	97	0	98	0	17	0	96	0	0
LUAD	439	294	356	0	430	32	353	0	365	237	229
LUSC	376	327	343	0	359	154	223	0	332	195	178
OV	592	580	566	0	557	575	297	570	454	412	316
PAAD	57	0	48	0	40	0	0	0	34	0	0
PANCAN8	4086	3882	3907	210	3798	2150	2515	1061	3169	2282	2152
PRAD	180	127	171	0	172	0	140	0	170	0	83
READ	169	168	162	35	162	69	72	0	143	130	69
SARC	29	0	29	0	29	0	0	0	29	0	0
SKCM	273	138	253	101	253	0	247	0	240	164	0
STAD	238	162	144	0	145	0	43	0	134	0	116
THCA	435	218	330	94	353	0	254	0	349	224	323
UCEC	512	451	493	106	500	54	333	0	485	200	248
Totals	7106	5839	6195	501	6443	2225	4357	1061	5627	3173	3166

Don't Scale to TCGA

November 14, 2012
Firehose Data Snapshot

Tumor	BCR	Clinical	CN	LowP	Methylation	mRNA	mRNAseq	miR	miRseq	RPPA	MAF
BLCA	153	108	99	0	138	0	96	0	124	54	28
BRCA	914	866	874	0	889	529	805	0	868	408	507
CESC	122	32	102	0	122	0	0	0	122	0	36
COAD	423	423	413	69	420	155	192	0	407	269	155
COADREAD	592	591	575	104	582	224	264	0	550	399	224
DLBC	28	0	17	0	17	0	0	0	16	0	0
GBM	598	565	563	0	411	542	161	491	0	214	276
HNSC	328	315	294	96	310	0	303	0	309	212	0
KICH	0	0	0	0	0	0	0	0	0	0	0
KIRC	0	0	0	0	0	72	469	0	480	454	403
KIRP	0	0	0	0	0	16	63	0	103	0	0
LAML	0	0	0	0	0	0	179	0	187	0	199
LGG	0	0	0	0	0	27	110	0	180	0	0
LIHC	99	62	97	0	98	0	17	0	96	0	0
LUAD	439	294	356	0	430	32	353	0	365	237	229
LUSC	376	327	343	0	359	154	223	0	332	195	178
OV	592	580	566	0	557	575	297	570	454	412	316
PAAD	57	0	48	0	40	0	0	0	34	0	0
PANCAN8	4086	3882	3907	210	3798	2150	2515	1061	3169	2282	2152
PRAD	180	127	171	0	172	0	140	0	170	0	83
READ	169	168	162	35	162	69	72	0	143	130	69
SARC	29	0	29	0	29	0	0	0	29	0	0
SKCM	273	138	253	101	253	0	247	0	240	164	0
STAD	238	162	144	0	145	0	43	0	134	0	116
THCA	435	218	330	94	353	0	254	0	349	224	323
UCEC	512	451	493	106	500	54	333	0	485	200	248
Totals	7106	5839	6195	501	6443	2225	4357	1061	5627	3173	3166
	+1830	+1665	+2021		+4181						+1142

**Diffs since Nov 2011
(~11K samples)**

Don't Scale to TCGA

November 14, 2012
Firehose Data Snapshot

Tumor	BCR	Clinical	CN	LowP	Methylation	mRNA	mRNAseq	miR	miRseq	RPPA	MAF
BLCA	153	108	99	0	138	0	96	0	124	54	28
BRCA	914	866	874	0	889	529	805	0	868	408	507
CESC	122	32	102	0	122	0	0	0	122	0	36
COAD	423	423	413	69	420	155	192	0	407	269	155
COADREAD	592	591	575	104	582	224	264	0	550	399	224
DLBC	28	0	17	0	17	0	0	0	16	0	0
GBM	598	565	563	0	411	542	161	491	0	214	276
HNSC	328	315	294	96	310	0	303	0	309	212	0
KICH						0					0
KIRC						72					403
KIRP						16					0
LAML						0					199
LGG						27					0
LIHC	99	62	97	0	98	0	17	0	96	0	0
LUAD	439	294	356	0	430	32	353	0	365	237	229
LUSC	376	327	343	0	359	154	223	0	332	195	178
OV	592	580	566	0	557	575	297	570	454	412	316
PAAD	57	0	48	0	40	0	0	0	34	0	0
PANCAN8	4086	3882	3907	210	3798	2150	2515	1061	3169	2282	2152
PRAD	180	127	171	0	172	0	140	0	170	0	83
READ	169	168	162	35	162	69	72	0	143	130	69
SARC	29	0	29	0	29	0	0	0	29	0	0
SKCM	273	138	253	101	253	0	247	0	240	164	0
STAD	238	162	144	0	145	0	43	0	134	0	116
THCA	435	218	330	94	353	0	254	0	349	224	323
UCEC	512	451	493	106	500	54	333	0	485	200	248
Totals	7106	5839	6195	501	6443	2225	4357	1061	5627	3173	3166
	+1830	+1665	+2021	+501	+4181		+4357		+5267	+3173	+1142

**Diffs since Nov 2011
(~11K samples)**

**New data types
(12.5K samples)**

Don't Scale to TCGA

November 14, 2012
Firehose Data Snapshot

Tumor	BCR	Clinical	CN	LowP	Methylation	mRNA	mRNAseq	miR	miRseq	RPPA	MAF
BLCA	153	108	99	0	138	0	96	0	124	54	28
BRCA	914	866	874	0	889	529	805	0	868	408	507
CESC	122	32	102	0	122	0	0	0	122	0	36
COAD	423	423	413	69	420	155	192	0	407	269	155
COADREAD	592	591	575	104	582	224	264	0	550	399	224
DLBC	28	0	17	0	17	0	0	0	16	0	0
GBM	598	565	563	0	411	542	161	491	0	214	276
HNSC	328	315	294	96	310	0	303	0	309	212	0
KICH						0					0
KIRC						72					403
KIRP						16					0
LAML						0					199
LGG						27					0
LIHC	99	62	97	0	98	0	17	0	96	0	0
LUAD	439	294	356	0	430	32	353	0	365	237	229
LUSC	376	327	343	0	350	154	223	0	332	195	178
OV	592	580						570	454	412	316
PAAD	57	0						0	34	0	0
PANCAN8	4086	3882						1061	3169	2282	2152
PRAD	180	127						0	170	0	83
READ	169	168						0	143	130	69
SARC	29	0	29	0	29	0	0	0	29	0	0
SKCM	273	138	253	101	253	0	247	0	240	164	0
STAD	238	162	144	0	145	0	43	0	134	0	116
THCA	435	218	330	94	353	0	254	0	349	224	323
UCEC	512	451	493	106	500	54	333	0	485	200	248
Totals	7106	5839	6195	501	6443	2225	4357	1061	5627	3173	3166
	+1830	+1665	+2021	+501	+4181		+4357		+5267	+3173	+1142

**Diffs since Nov 2011
(~11K samples)**

**New data types
(12.5K samples)**

**Last year: ~24K
new samples**

Acute Need for Automation, Systematic Rigor, and Transparency



GDAC Firehose == Virtual Data Factory

Broad Institute TCGA GDAC Internal Process Flow

Version 2011_04_11

Subject to Same Engineering Constraints of Timeliness, Transparency & Rigor as Physical Factories

Not academic one-off

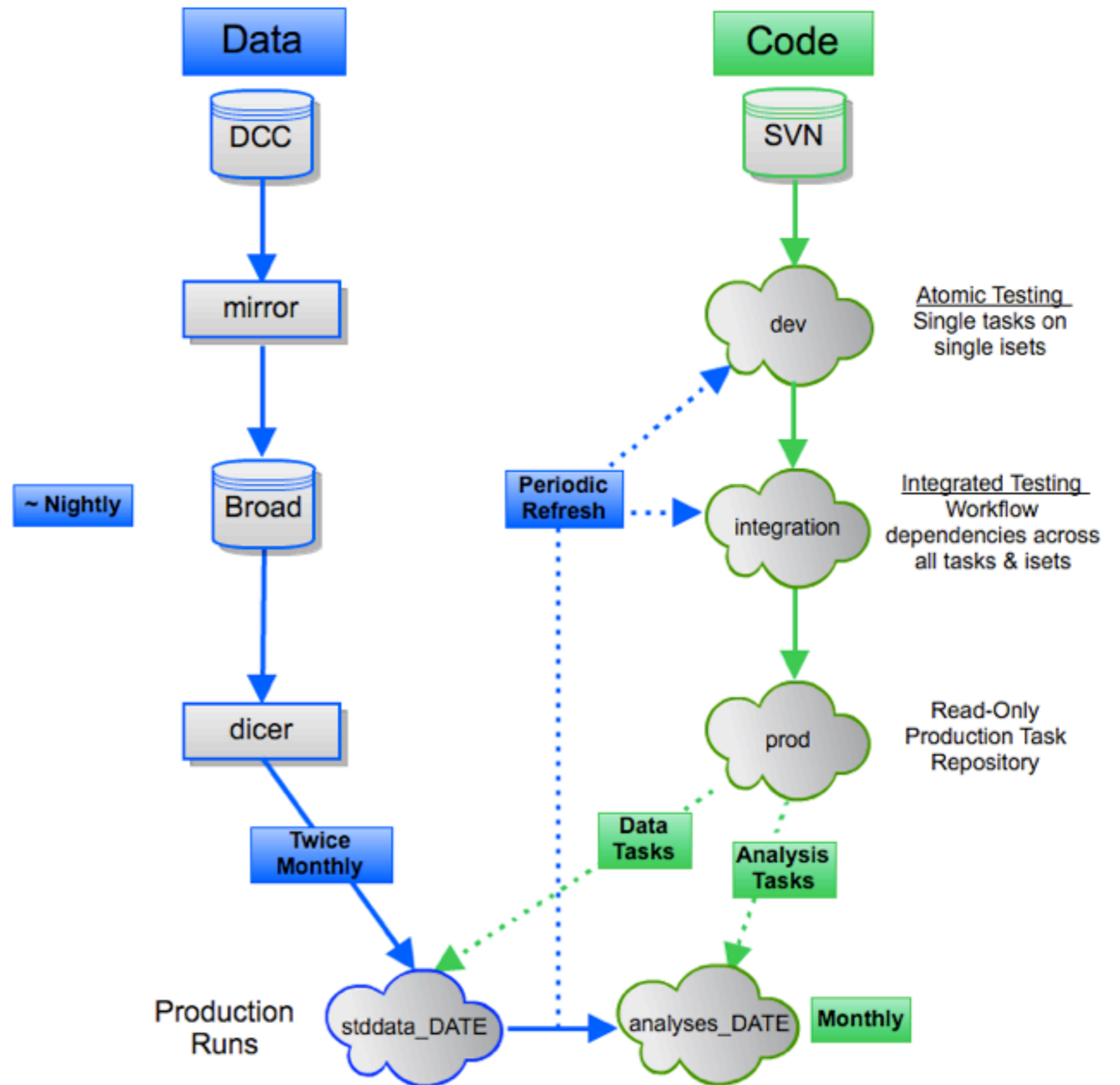

II. TCGA NOVEMBER 2012 THE DATA FLOOD CONTINUES



II. TCGA NOVEMBER 2012

THE DATA FLOOD CONTINUES



- 7K patient cases, heading to 11K total
- 26 tumor cohorts (plus clinical)
- 6 marker papers published, more underway
- Swirling amongst 20 centers nationwide (and ICGC)

Understanding TCGA : data flow & levels

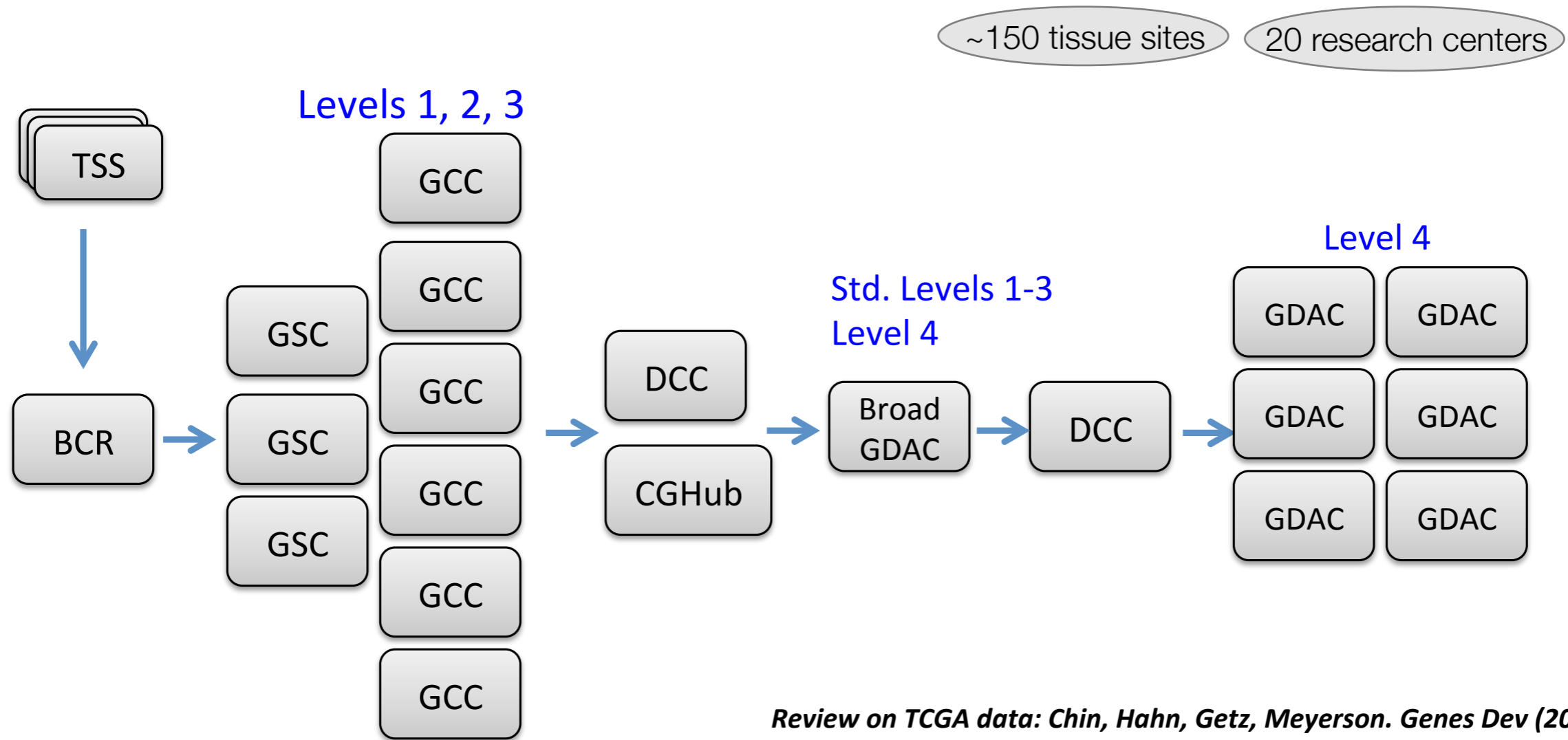

Review on TCGA data: Chin, Hahn, Getz, Meyerson. *Genes Dev* (2011)

Purpose 1: Characterization:

Level 1 – Raw data (e.g. raw reads and qualities, Affymetrix CEL files)

Level 2 – Normalized data (e.g. aligned reads – BAM files, intensity matched files)

Level 3 – Genomic events (e.g. somatic mutations, segments of copy number changes)

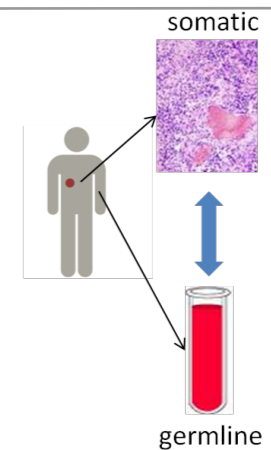

Purpose 2: Interpretation:

Level 4 – Analysis across a cohort (e.g. sub-types discovery, correlate data types, significantly mutated genes/regions/pathways, correlation to clinical parameters)



Broad Contribution: 3 of 20 research centers

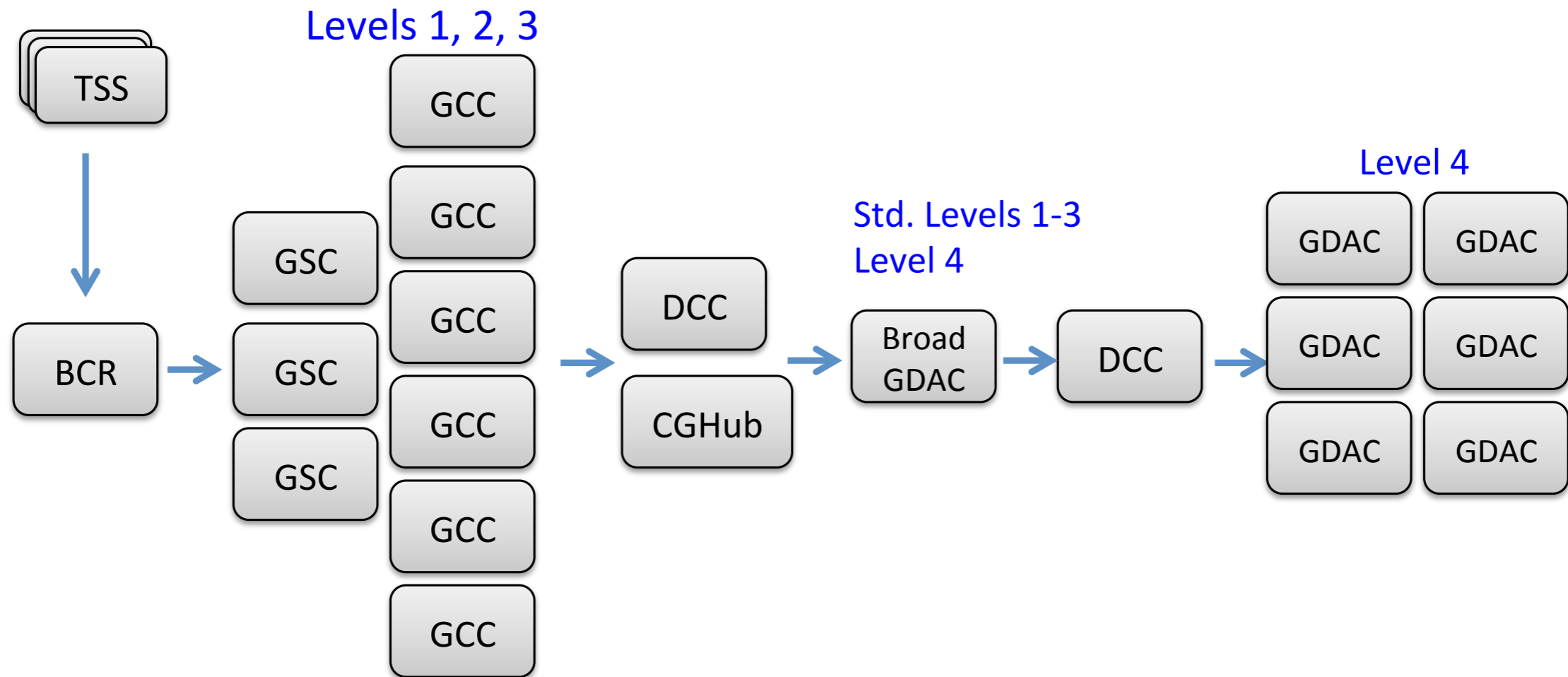

Broad Contribution: 3 of 20 research centers

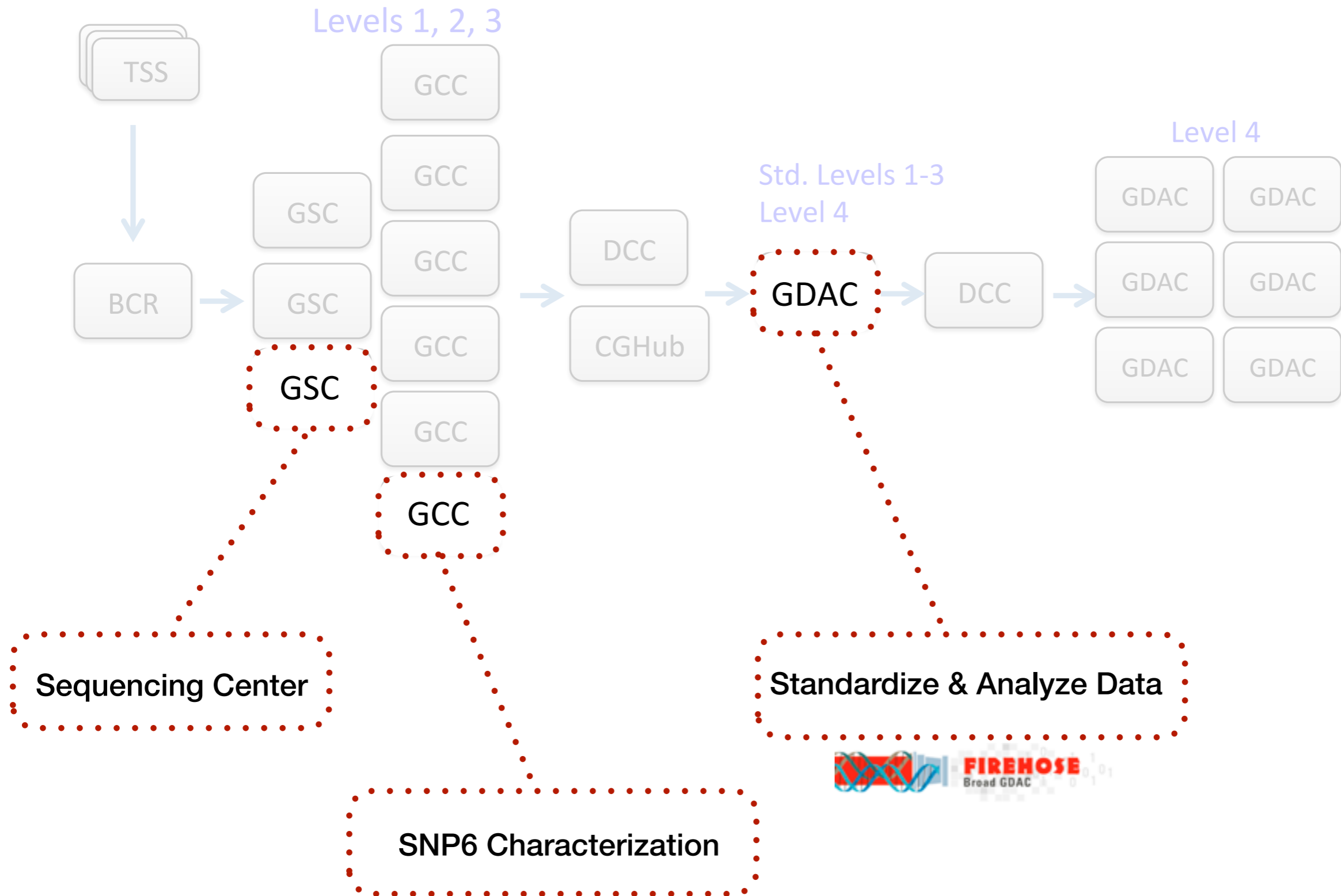

Flowing Into Other Portals



stddata__2012_MM_DD
analyses__2012_MM_DD

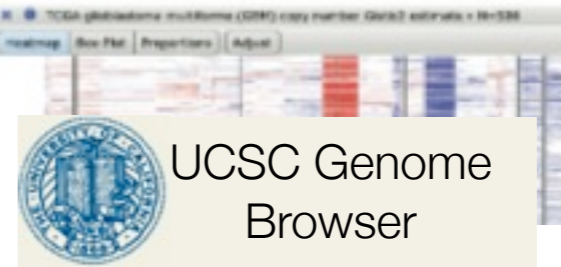
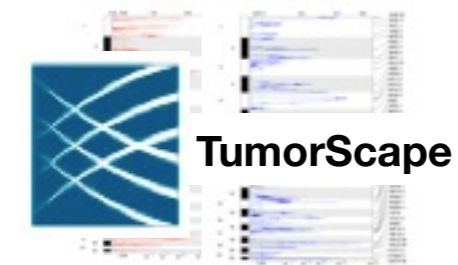

BUT HOW IS DATA STREAM USED TO ANSWER COMMON BIOLOGICAL QUESTIONS?

- Such as:

Is my gene of interest altered in this tumor type? How?

Is that alteration significantly above the background rate?

How might those features map to clinical or molecular feature X?

BUT HOW IS DATA STREAM USED TO ANSWER COMMON BIOLOGICAL QUESTIONS?

- Such as:

Is my gene of interest altered in this tumor type? How?

Is that alteration significantly above the background rate?

How might those features map to clinical or molecular feature X?

- There is no one-size-fits-all, cookie-cutter method to answer such questions

BUT HOW IS DATA STREAM USED TO ANSWER COMMON BIOLOGICAL QUESTIONS?

- Such as:

Is my gene of interest altered in this tumor type? How?
Is that alteration significantly above the background rate?
How might those features map to clinical or molecular feature X?

- There is no one-size-fits-all, cookie-cutter method to answer such questions
- But some analyses are common to many questions and can be automated:
 - ▶ Mutation calling, classifying, summarizing and significance-testing
 - ▶ Copy number alteration detection and significance-testing
 - ▶ Expression- and methylation-based clustering
 - ▶ Associating genomic data with common clinical, treatment or survival groups

- These common results then become building blocks for higher-level analysis

- These common results then become building blocks for higher-level analysis
- So downstream users do not have to repeat each time
(e.g. automation a boon when 20 new samples added to 250)

- These common results then become building blocks for higher-level analysis
- So downstream users do not have to repeat each time
(e.g. automation a boon when 20 new samples added to 250)
- Nor perform ad-hoc reinvention of methods
- Nor download all low-level data from which they were generated

- These common results then become building blocks for higher-level analysis
- So downstream users do not have to repeat each time
(e.g. automation a boon when 20 new samples added to 250)
- Nor perform ad-hoc reinvention of methods
- Nor download all low-level data from which they were generated
- Nor institute their own ad-hoc data freeze/versioning scheme
- ... to ensure accuracy & reproducibility of analytic/statistical results

- These common results then become building blocks for higher-level analysis
- So downstream users do not have to repeat each time
(e.g. automation a boon when 20 new samples added to 250)
- Nor perform ad-hoc reinvention of methods
- Nor download all low-level data from which they were generated
- Nor institute their own ad-hoc data freeze/versioning scheme
- ... to ensure accuracy & reproducibility of analytic/statistical results
- Nor institute ad-hoc QC program ... to minimize human error in large-data analyses

- These common results then become building blocks for higher-level analysis
- So downstream users do not have to repeat each time
(e.g. automation a boon when 20 new samples added to 250)
- Nor perform ad-hoc reinvention of methods
- Nor download all low-level data from which they were generated
- Nor institute their own ad-hoc data freeze/versioning scheme
- ... to ensure accuracy & reproducibility of analytic/statistical results
- Nor institute ad-hoc QC program ... to minimize human error in large-data analyses

**Firehose aims to address such concerns, at scale,
lowering the entry barrier for TCGA utilization**

Must be Simple, Flexible, Easy ... because



This is Your
Researcher
Brain

Must be Simple, Flexible, Easy ... because

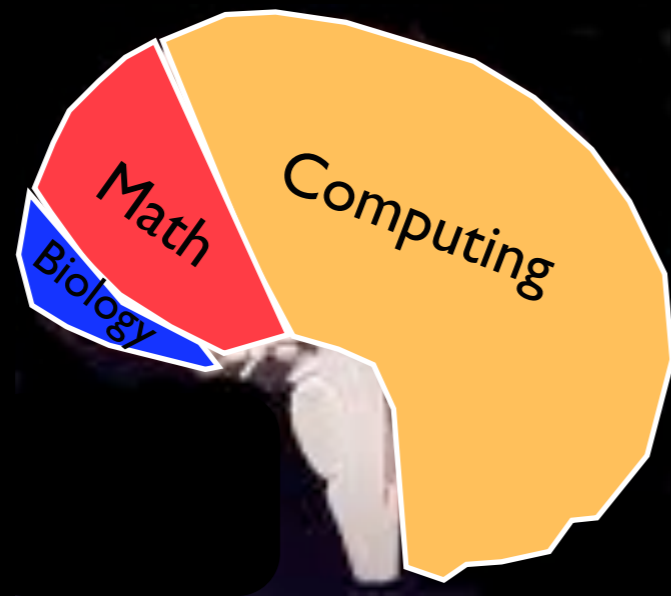

When Coding
Or Data
Exploration
Is Hard

Must be Simple, Flexible, Easy ... because

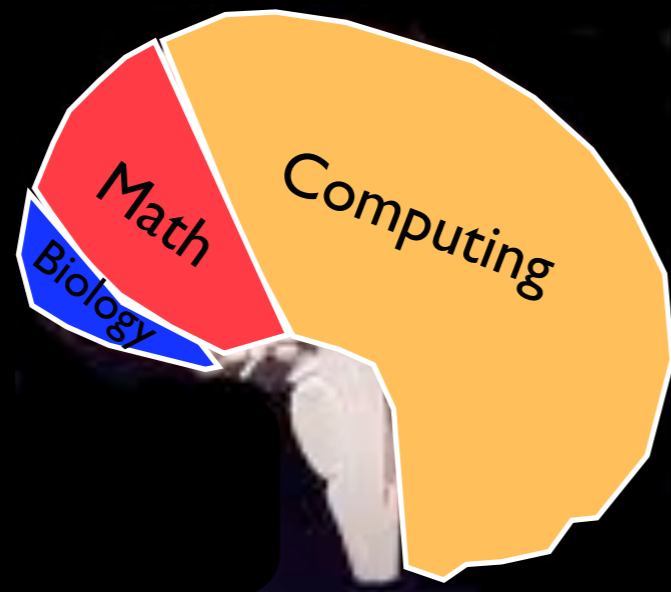

When Coding
Or Data
Exploration
Is Hard

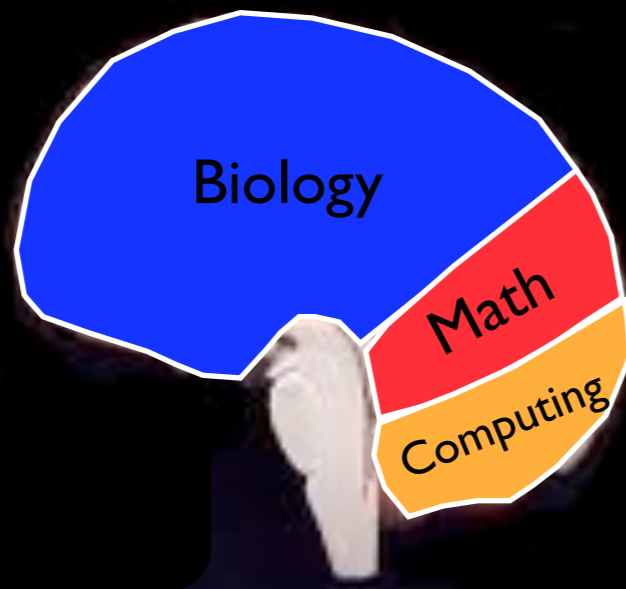

When
Easier

Must be Simple, Flexible, Easy ... because

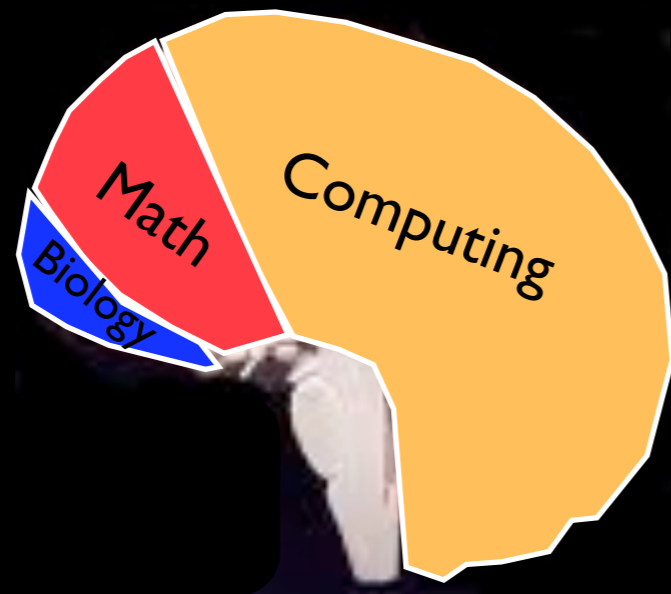

When Coding
Or Data
Exploration
Is Hard

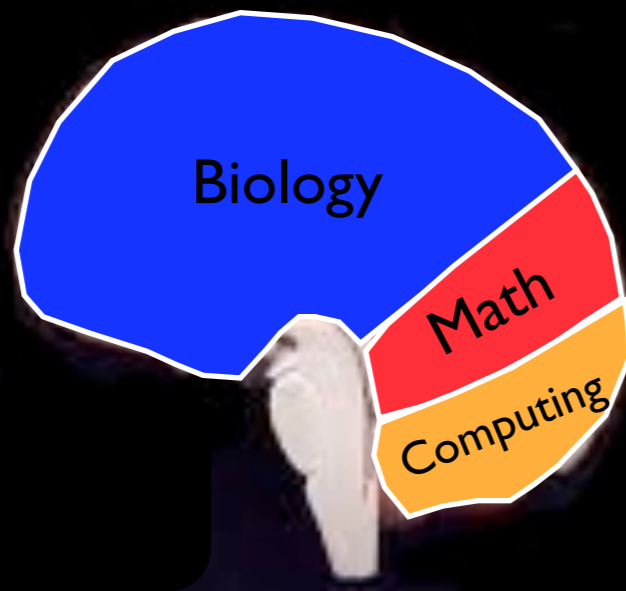

When
Easier

Civilization advances by extending the number of important operations which we can perform without thought.

A. North Whitehead

III. So Firehose Data Factory Produces

- 1 Version-stamped, standardized datasets (2X / month)
- 2 Regular package of standard analyses results (1X / month)
- 3 Companioned with biologist-friendly reports (475 / month)

III. So Firehose Data Factory Produces

1 Version-stamped, standardized datasets (2X / month)

*Precursor to automated analyses, durable (DCC) & citable
Minimizing effect of **The Babel Problem***

2 Regular package of standard analyses results (1X / month)

3 Companioned with biologist-friendly reports (475 / month)

III. So Firehose Data Factory Produces

1 Version-stamped, standardized datasets (2X / month)

*Precursor to automated analyses, durable (DCC) & citable
Minimizing effect of **The Babel Problem***

2 Regular package of standard analyses results (1X / month)

For vetted algorithms: GISTIC, MutSig, CNMF, ...

3 Companioned with biologist-friendly reports (475 / month)

III. So Firehose Data Factory Produces

1 Version-stamped, standardized datasets (2X / month)

*Precursor to automated analyses, durable (DCC) & citable
Minimizing effect of **The Babel Problem***

2 Regular package of standard analyses results (1X / month)

For vetted algorithms: GISTIC, MutSig, CNMF, ...

3 Companioned with biologist-friendly reports (475 / month)

*Instantly up-to-speed on current TCGA results
(zero time/budget/staff investment)*

Both Archival & Active Research by TCGA AWGs

2012_08_25 awg_pancan8 Analyses Run

Tables of Ingested Data: [HTML](#) [PNG](#) [TSV](#) Redactions: [Report](#)

AnalysisReport	# Pipelines	% Successful
BRCA	35	100%
COADREAD	35	100%
GBM	34	100%
KIRC	35	100%
LUSC	35	100%
OV		
UCEC		
PANCAN		

Analysis Overview for Thyroid Adenocarcinoma: 2012_10_24

Maintained by [TCGA GDAC Team](#) (Broad Institute/Dana-Farber Cancer Institute/Harvard Medical School)

Unique Tumor Sample Counts

Tumor	BCR	Clinical	CN	LowP	Methylation	mRNA	mRNAseq	miR	miRseq	RPPA	MAF
THCA	435	218	330	94	353	0	254	0	349	224	323

Analysis Overview for Lung Adenocarcinoma: 2012_11_15

Maintained by [TCGA GDAC Team](#) (Broad Institute/Dana-Farber Cancer Institute/Harvard Medical School)

Unique Tumor Sample Counts

Tumor	BCR	Clinical	CN	LowP	Methylation	mRNA	mRNAseq	miR	miRseq	RPPA	MAF
LUAD	439	294	358	0	432	32	355	0	366	237	229

Download run results with [firehose_get version 0.3.8](#)

Download command: `firehose_get awg_luad 2012_11_15`

[Task Dashboard](#)

- Overview
- Introduction
- Summary

Note: These results are offered to the community as an additional reference point, enabling a wide range of cancer biologists, clinical investigators, and genome and computational scientists to easily incorporate TCGA into the backdrop of ongoing research. While every effort is made to ensure that Firehose input data and algorithms are of the highest possible quality, these analyses have not been reviewed by domain experts.

[firehose_get version 0.3.8](#)

reference point, enabling a wide range of cancer biologists, easily incorporate TCGA into the backdrop of ongoing research. While every effort is made to ensure that Firehose input data and algorithms are of the highest possible quality, these analyses have not been reviewed by domain experts.

UCEC
SKCM
LUSC

Unprecedented Scale: KiloPipeline per Month

stddata__2012_10_04

547 datasets submitted to DCC

stddata__2012_10_24

940 datasets ...

analyses__2012_10_24

837 analyses ...

2324 pipelines across 26 disease cohorts

Unprecedented Scale: KiloPipeline per Month

stddata__2012_10_04
stddata__2012_10_24
analyses__2012_10_24

547 datasets submitted to DCC
940 datasets ...
837 analyses ...

2324 pipelines across 26 disease cohorts

*With up to 33
biologist-friendly
analysis reports
per disease
(475 reports in all)*

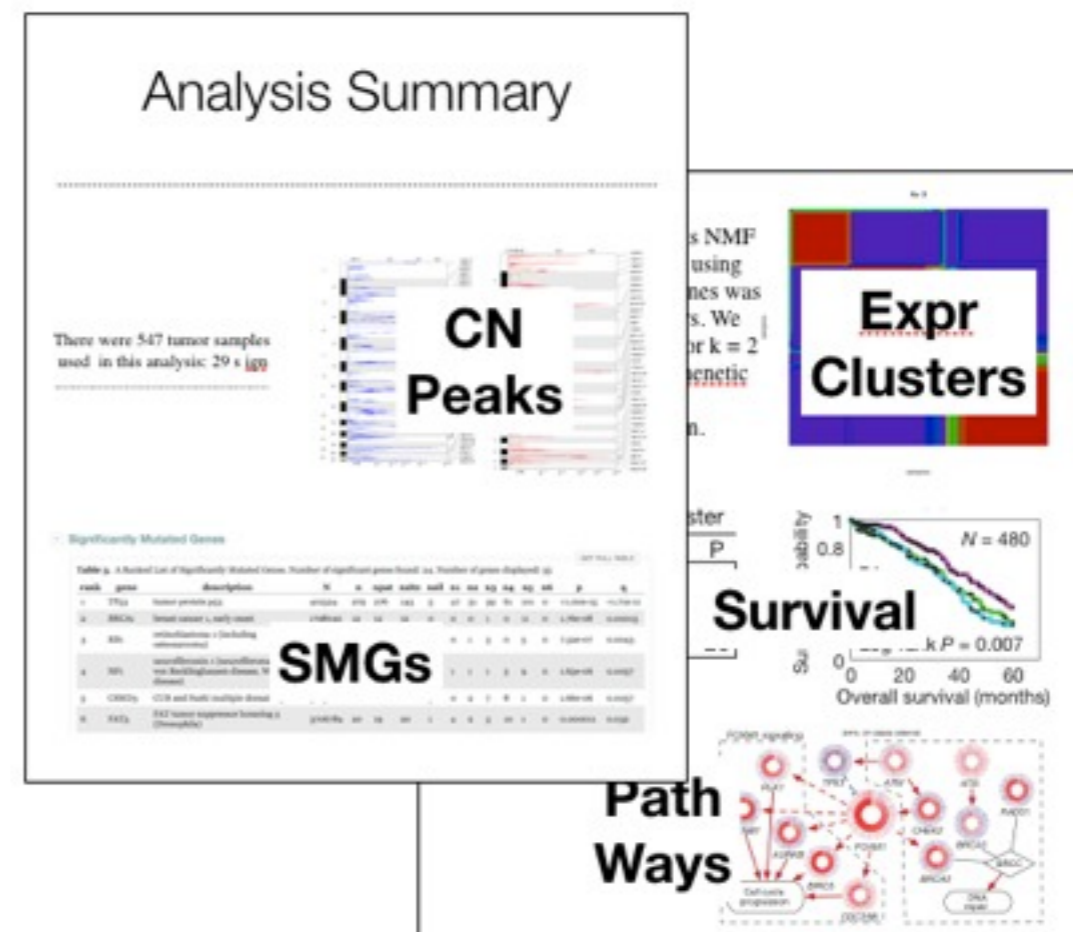

Unprecedented Scale: KiloPipeline per Month

stddata__2012_10_04
stddata__2012_10_24
analyses__2012_10_24

547 datasets submitted to DCC
940 datasets ...
837 analyses ...

2324 pipelines across 26 disease cohorts

*With up to 33
biologist-friendly
analysis reports
per disease
(475 reports in all)*

Single Month: Oct 2012

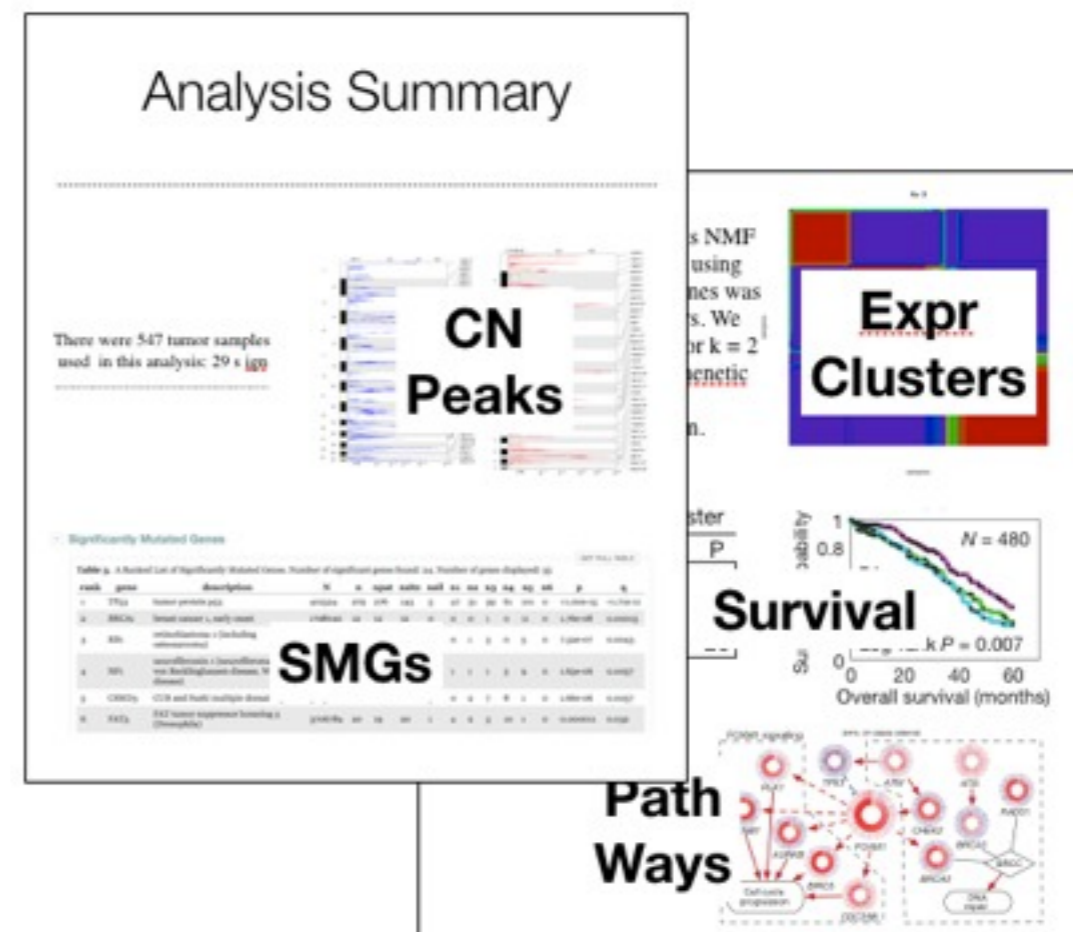

Again: Not Mutually Exclusive With **“Easy”**

%	gdac_diff	2012_09_13	2012_10_04	\$PANCAN8
	mRNAseq	+161	(2304 total)	
	CN	+125	(3907 total)	
	Methylation	+30	(3667 total)	
	Clinical	+30	(3864 total)	
	BCR	+16	(4086 total)	

2 seconds to understand sample diffs in 35+ terabytes

Again: Not Mutually Exclusive With **“Easy”**

% gdac_diff	2012_09_13	2012_10_04	\$PANCAN8
mRNAseq	+161	(2304 total)	
CN	+125	(3907 total)	
Methylation	+30	(3667 total)	
Clinical	+30	(3864 total)	
BCR	+16	(4086 total)	

2 seconds to understand sample diffs in 35+ terabytes

Version stamp: rigor & clarity → ease

Easy Corroboration: first-pass, low hanging fruit

- Enable readers ([PIs](#), [bench bios](#), [clinical trialists](#), [DotComs](#))
- To quickly take pulse of TCGA for given disease type(s)
- With just a few glances at common representational figures
- Not deep head-scratching or big time investment

Easy Corroboration: first-pass, low hanging fruit

- Enable readers (PIs, bench bios, clinical trialists, DotComs)
- To quickly take pulse of TCGA for given disease type(s)
- With just a few glances at common representational figures
- Not deep head-scratching or big time investment

“Oh, that’s interesting, maybe my code has found something here ... I wonder if this is seen in the Firehose version 2012_07_25 results, too?”

Easy Corroboration: first-pass, low hanging fruit

- Enable readers (PIs, bench bios, clinical trialists, DotComs)
- To quickly take pulse of TCGA for given disease type(s)
- With just a few glances at common representational figures
- Not deep head-scratching or big time investment

“Oh, that’s interesting, maybe my code has found something here ... I wonder if this is seen in the Firehose version 2012_07_25 results, too?”

Durability of DCC archive fosters citable referencing:

“Our analyses were performed against TCGA dataset version 2012_07_25, and validated against ...

Easy Corroboration: first-pass, low hanging fruit

- Enable readers (PIs, bench bios, clinical trialists, DotComs)
- To quickly take pulse of TCGA for given disease type(s)
- With just a few glances at common representational figures
- Not deep head-scratching or big time investment

“Oh, that’s interesting, maybe my code has found something here ... I wonder if this is seen in the Firehose version **2012_07_25** results, too?”

Durability of DCC archive fosters citable referencing:

“Our analyses were performed against TCGA dataset version **2012_07_25** and validated against ...”

BUT MIND THE FINE PRINT

These results are offered to the community as an additional reference point, enabling a wide range of cancer biologists, clinical investigators, and genome & computational scientists to easily incorporate TCGA into the backdrop of ongoing research.

BUT MIND THE FINE PRINT

These results are offered to the community as an additional reference point, enabling a wide range of cancer biologists, clinical investigators, and genome & computational scientists to easily incorporate TCGA into the backdrop of ongoing research.

STARTING POINT : NOT FINAL WORD

AUTOMATIC MACHINES ARE DUMB & IMPERFECT

EXPERT JUDGEMENT STILL REQUIRED

BUT MIND THE FINE PRINT

These results are offered to the community as an additional reference point, enabling a wide range of cancer biologists, clinical investigators, and genome & computational scientists to easily incorporate TCGA into the backdrop of ongoing research.

STARTING POINT : NOT FINAL WORD

AUTOMATIC MACHINES ARE DUMB & IMPERFECT
EXPERT JUDGEMENT STILL REQUIRED

`firehose2nature` tool is organic, not in-silico

Future Potential: Automated Clinical Gold Mine?

Wealth of clinical data collected by TCGA

To date underrepresented in TCGA-based publications

Understandable byproduct of complex mix of

scientific, technological & operational factors

But clear steps can be taken to minimize extent that

Sheer volume & complexity ... **alone** ...

Impede fuller exploitation of clinical in TCGA-based work

Firehose automatically mines entire suite of clinical params to identify statistically significant relationships with every TCGA datatype or aggregate (e.g. clusters)

The results, which e.g. include survival curves (when possible) for every TCGA disease, are posted openly on the Broad GDAC site in the form of biologist-friendly HTML reports

Since automation is free, these don't have to be 100% to establish potentially interesting signposts

Precedent in 2011 Ovarian Manuscript

Given richness of TCGA data stream,
Discoveries lurk in our GDAC pipeline outputs

Precedent in 2011 Ovarian Manuscript

d

miRNA cluster	Gene cluster			
	D	I	M	P
C1	55	48	15	89
C2	40	21	51	29
C3	39	37	43	20

CNMF clustering of OV miR expression yielded 3 subtypes

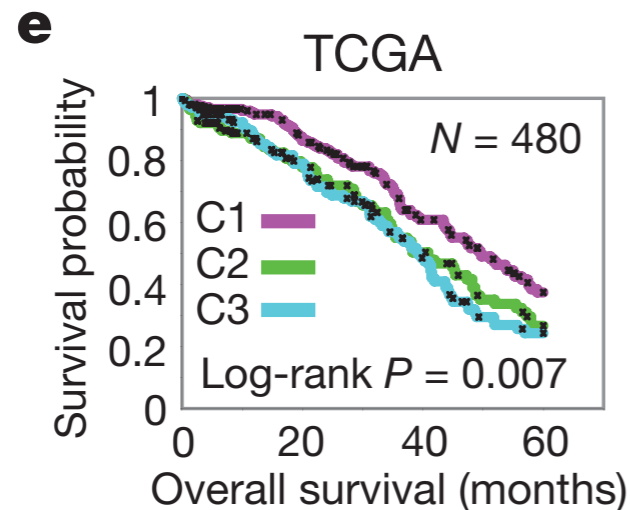

One of which correlated to significantly longer survivability

***Integrated genomic analyses of ovarian carcinoma
TCGA Network, Nature, June 2011***

Given richness of TCGA data stream,
Discoveries lurk in our GDAC pipeline outputs

LUSC

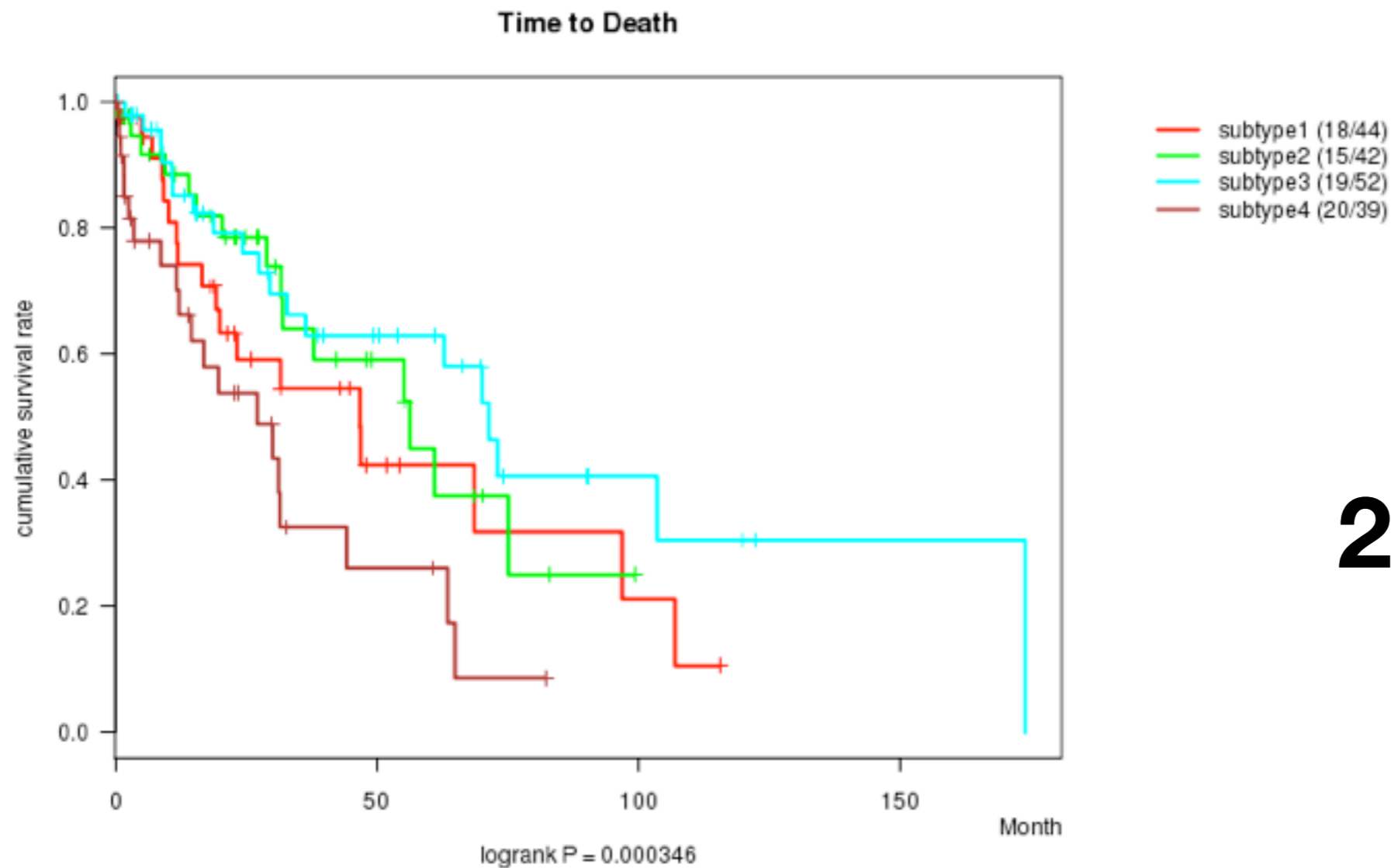

2012_09_13
Analyses

	nPatients	nDeath	Duration Range (Median), Month
ALL	177	72	0.0 - 173.8 (16.6)
subtype1	44	18	0.2 - 115.6 (14.3)
subtype2	42	15	0.2 - 99.2 (23.0)
subtype3	52	19	0.0 - 173.8 (17.8)
subtype4	39	20	0.1 - 82.2 (8.8)

'RPPA cHierClus subtypes' versus 'Time to Death'
P value = 0.000346 (logrank test)

KIRC

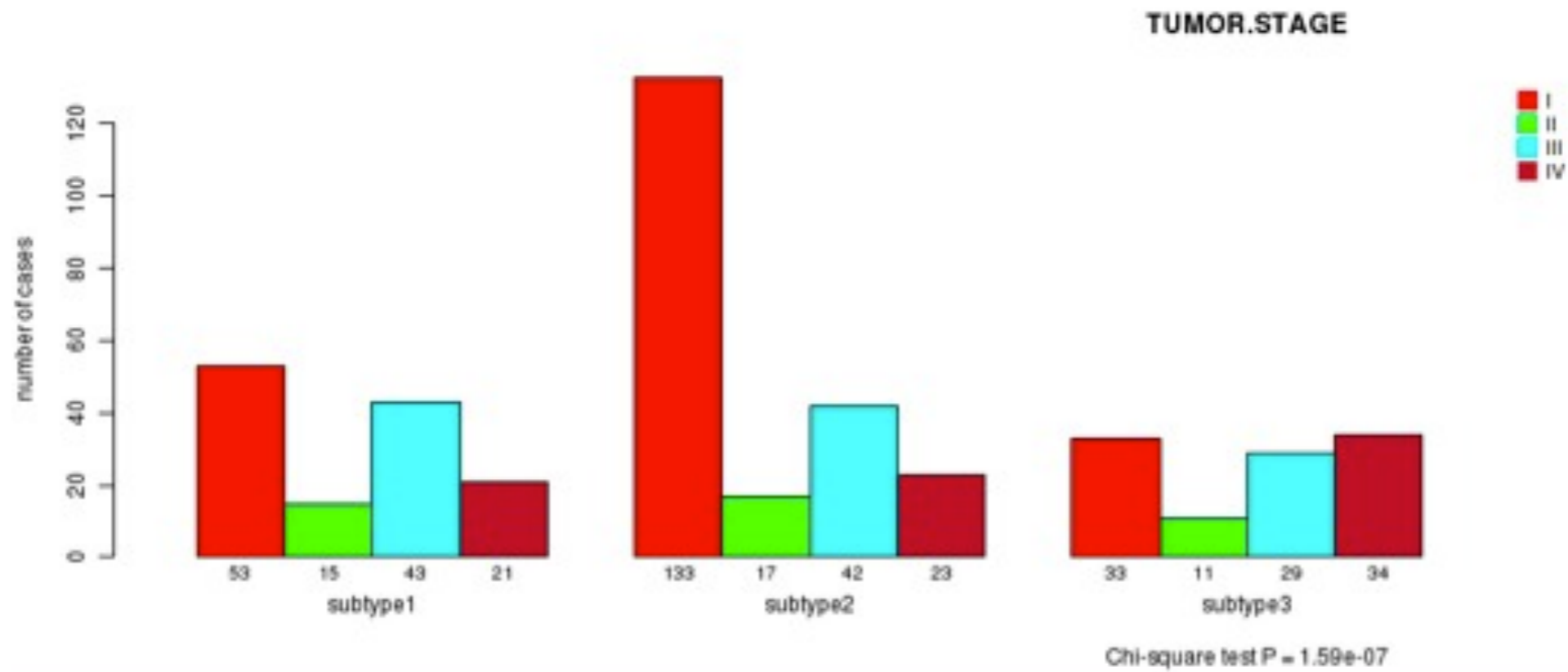

nPatients	I	II	III	IV
ALL	219	43	114	78
subtype1	53	15	43	21
subtype2	133	17	42	23
subtype3	33	11	29	34

'RPPA cHierClus subtypes' versus 'TUMOR.STAGE'

P value = 1.59e-07 (Chi-square test)

UCEC

Correlation between RPPA expression and '*HISTOLOGICAL.TYPE*'

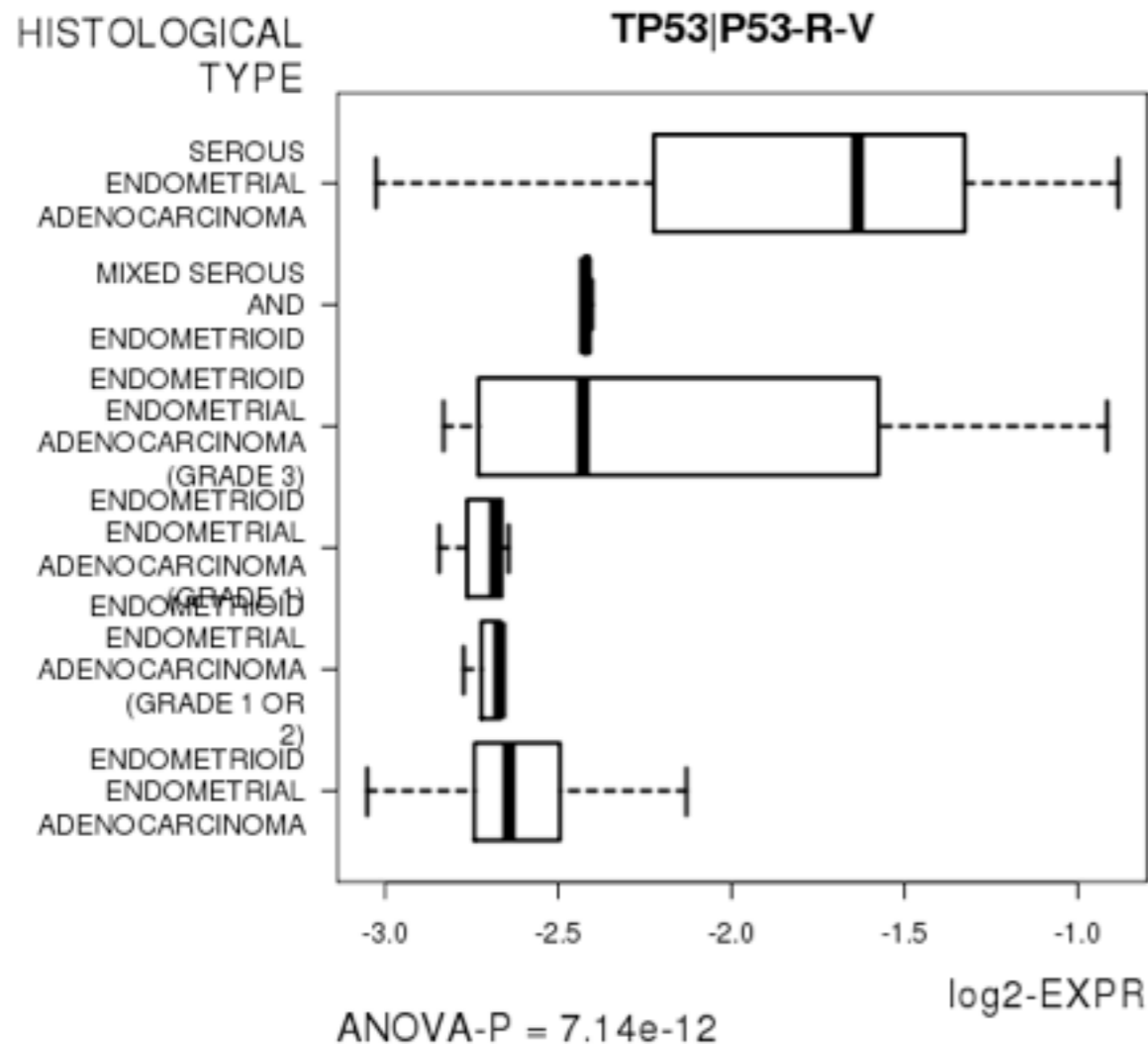

	ANOVA_P	Q
TP53 P53-R-V	7.144e-12	1.19e-09
CHEK2 CHK2_PT68-R-C	7.824e-09	1.29e-06
AKT1 AKT2 AKT3 AKT_PS473-R-V	6.908e-08	1.13e-05
PGR PR-R-V	1.307e-07	2.13e-05
CDC2 CDK1-R-V	2.576e-07	4.17e-05
CDH1 E-CADHERIN-R-V	2.644e-07	4.26e-05
ESR1 ER-ALPHA-R-V	9.567e-07	0.000153
ESR1 ER-ALPHA_PS118-R-V	3.992e-06	0.000635
EEF2 EEF2-R-V	7.75e-06	0.00122
EIF4EBP1 4E-BP1_PS65-R-V	1.874e-05	0.00294

IV. How To Access

2012_10_24 stddata Run

DiseaseType	# Datasets	% Processed	Download
BLCA	38	100%	Open Protected
BRCA	48	100%	Open Protected
CESC	20	100%	Open Protected
COADREAD	38	100%	Open Protected
COAD	38	100%	Open Protected
DLBC	13	100%	Open Protected
GBM	51	100%	Open Protected
HNSC	40	100%	Open Protected
KICH			Open Protected
KIRC			Open Protected
KIRP			Open Protected
LAML			Open Protected
LGG			Open Protected
LHCC			Open Protected
LUAD			Open Protected
LUSC			Open Protected
OV	57	100%	Open Protected
PAAD	14	100%	Open Protected
PRAD	30	100%	Open Protected
READ	38	100%	Open Protected
SARC	13	100%	Open Protected
SKCM	24	100%	Open Protected
STAD	27	100%	Open Protected
THCA	40	100%	Open Protected
UCEC	48	100%	Open Protected
PANCANB	87	95%	Open Protected

Data
Dashboard

2012_10_24 analyses Run

AnalysisReport	# Pipelines	% Successful	Download
BLCA	36	100%	Open Protected
BRCA	44	100%	Open Protected
CESC	26	100%	Open Protected
COADREAD	44	100%	Open Protected
COAD	44	100%	Open Protected
GBM	46	100%	Open Protected
HNSC	18	100%	Open Protected
KIRC	44	100%	Open Protected
KIRP			Open Protected
LAML			Open Protected
LGG			Open Protected
LHCC			Open Protected
LUAD			Open Protected
LUSC			Open Protected
OV			Open Protected
PAAD			Open Protected
PRAD	33	100%	Open Protected
READ	44	100%	Open Protected
SARC	7	100%	Open Protected
SKCM	25	100%	Open Protected
STAD	31	100%	Open Protected
THCA	37	100%	Open Protected
UCEC	44	100%	Open Protected
DLBC	7	88%	Open Protected
KICH	6	75%	Open Protected
PANCANB	9	56%	Open Protected

Analysis
Dashboard

<http://gdac.broadinstitute.org>

Open Public Resource

Interactive Desktop Use

Nexus Resource for Evolving Community

- Thousands of views, 140K+ hits / month
- Hundreds of GB downloads / month
- Across dozens of centers & portals
- Research / Academic / Commercial
- National & International
- Beyond genomics : e.g. CPTAC / proteomics

Nexus Resource for Evolving Community

- Thousands of views, 140K+ hits / month
- Hundreds of GB downloads / month
- Across dozens of centers & portals
- Research / Academic / Commercial
- National & International
- Beyond genomics : e.g. CPTAC / proteomics

(more useful than pretty, but facelift coming in 2013)

With Open (-Source) / Transparent Look & Feel

Q: Why does your [table of ingested data](#) show that *disease type XYZ* has *N* mutation samples?

A: Our precedence rules for ingesting mutation samples are:

1. Prefer manually-curated MAF from the respective analysis working group (AWG), on the premise that
2. When no AWG MAF is available, fall back to using what is available in the DCC by automatic subn
3. Otherwise Firehose will contain zero mutation samples for that disease type.

We're in the process of defining a fourth rule, however, to account for the evolving nature of TCGA mutati
accrue at the DCC (again, automatically submitted by the respective GSCs), and it is natural for analysts

For more information, please consult [our provenance table for mutation data](#), the [TCGA MAF workflow](#) and
will likely support VCFs once they become sufficiently prevalent in the TCGA dataflow.

Q: Why does your [table of ingested data](#) show that *disease type XYZ* has *N* methylation samples?

A: We ingest and support both of the major methylation platforms (meth450 and meth27), therefore the
statistical algorithms used by TCGA AWGs to merge both of these methylation platforms into a single bol
higher resolution data.

Q: What TCGA sample types are Firehose pipelines executed upon?

A: Since inception Firehose analyses have been executed upon tumor samples and then correlated with
exception is [melanoma \(SKCM\)](#), which we analyze using metastatic tumor samples (code 06) as it is usu
we will include a larger range of sample types, including normals.

Q: What do you do when multiple aliquot barcodes exist for a given sample/portion/analyte comb

A: To date GDAC analyses have proceeded upon one single tumor sample per patient, so when multiple
metrics, we use the following rules to make such selections:

1. Prefer B aliquots over T when DNA aliquots of both type exist

FAQ



Re: [GDAC-users] firehose - download normal expression values

Subject: **Re: [GDAC-users] firehose - download normal expression values** ([find more](#))
From: David Tamborero <hidden> ([find more](#))
Date: Aug 26, 2012 14:22

Thank you very much, your work and help is priceless.

2012/8/24 Michael S. Noble <hidden>

>
> Dear David,
>
> Apologies for the delay in responding. Yes, you are right: our outputs do
> not
> contain normals. This is partly a legacy held over from the TCGA pilot
> studies, which is where many of the analyses in our GDAC originally stem
> from. Our FAQ online at gdac.broadinstitute.org discusses this in the
> section
>
> Q: What TCGA sample types are Firehose pipelines executed upon?
>
> and points out that we aim to support normals in the Fall of 2012.
>
> Regards,
> Mike Noble
>

Searchable Mail Archive



Re: [GDAC-users] firehose - download normal expression values

Subject: Re: [GDAC-users] firehose - download normal expression values (find more)
 From: David Tamborero <hidden> (find more)
 Date: Aug 26, 2012 14:22

Thank you very much, your work and help is priceless.

2012/8/24 Michael S. Noble <hidden>

>
 > Dear David,
 >
 > Apologies for the delay in responding. Yes, you are right: our outputs do
 > not
 > contain normals. This is partly a legacy held over from the TCGA pilot
 > studies, which is where many of the analyses in our GDAC originally stem
 > from. Our FAQ online at gdac.broadinstitute.org discusses this in the
 > section
 >
 > Q: What TCGA sample types are Firehose pipelines
 >
 > and points out that we aim to support normals in the
 >
 > Regards,
 > Mike Noble
 >

Searchable Mail Archive

June 2012 (2012_06_23)

1. Increased number of archives generated from 777 to 993
2. Increased number of reports from 227 to 252
3. 2,244 new samples reflected since May analyses run, due to more data and better counting:
 - 76 LowP (new sample type - Low Pass DNaseq)
 - 230 BCR
 - 307 Clinical
 - 618 mRNAseq
 - 937 miRseq
 - 76 MAF
4. GISTIC2 report now includes a description of both the input and output files in the *Methods & Data* section
5. Methylation data:
 - Rewired pipelines to include meth450 platform, and also give it preference over meth27 when both are present. (Methods to combine 450 & 27 analytically are not in Firehose: would be nice for AWGs to provide if possible)
 - This greatly increases count of methylation samples flowing through analyses (e.g. UCEC 117-->363)
 - Most clusterings show similar results, but some are discordant with previous runs: we could use AWG help to evaluate, and will post comparative analysis online towards that end
6. New clustering pipelines heuristic: a sample will be dropped from analyses when 80% or more genes are absent.
7. mRNAseq: we now utilize maseqv2 archives, but fall back to v1 maseq when v2 is not available for a given tumor type
 - RSEM estimation used for downstream clustering & correlation analysis, when available, otherwise RPKM estimation will be used
 - RSEM is used to estimate gene and transcript abundances (<http://deweylab.biostat.wisc.edu/rsem/rsem-calculate-expression.html>); values are normalized to a fixed upper quartile value of 1000 for gene and 300 for transcript level estimates, and the normalized values are placed in a separate file (From the DCC document).
 - The following showed the boxplot of BRCA mRNAseq samples with log2 transformed RESM (left) and RPKM (right).

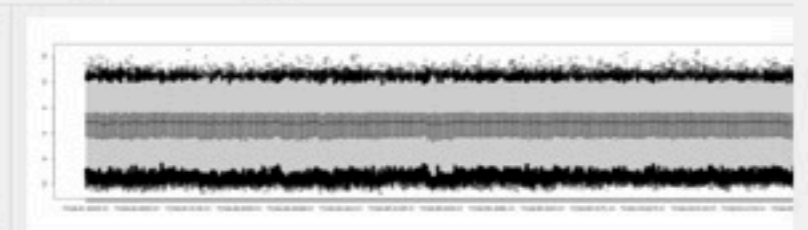
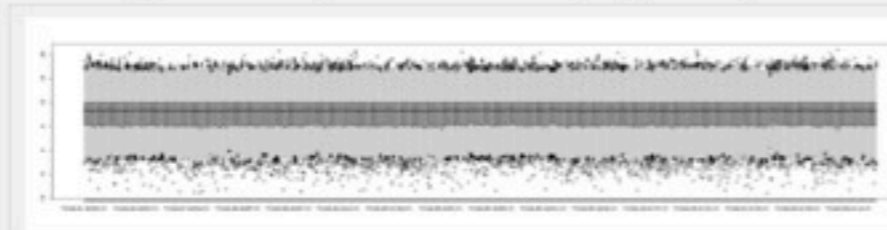

Detailed Release Notes

stddata dashboard

The Broad GDAC standardized data packages represent a frozen snapshot of all [TCGA](#) analysis data at a given time:

- **Cast in a form amenable to immediate algorithmic analysis** (no additional data preparation required)
- Which provides a **consistent point of reference** for analysis and [citation by marker papers and users](#) of TCGA data
- Towards a **formal definition** of what constitutes a given tumor dataset
- While **minimizing redundant effort** across centers and groups to download & prepare data for further analysis
- And **enhancing provenance and reproducibility**

2012_08_04 stddata Run

Tables of Ingested Data: [HTML](#) [PNG](#) [TSV](#) Redactions: [Report](#)

ReleaseNotes	# Datasets	% Processed	Download	
BLCA	20	100%	Open	Protected
BRCA	27	100%	Open	Protected
CESC	11	100%	Open	Protected
COADREAD	21	100%	Open	Protected
DLBC	5	100%	Open	Protected
GBM	27	100%	Open	Protected
HNSC	20	100%	Open	Protected
KIRC	27	100%	Open	Protected
KIRP	23	100%	Open	Protected
LAML	11	100%	Open	Protected
LGG	17	100%	Open	Protected
LIHC	17	100%	Open	Protected
LUAD	26	100%	Open	Protected
LUSC	34	100%	Open	Protected
OV	32	100%	Open	Protected
PAAD	6	100%	Open	Protected
PRAD	16	100%	Open	Protected
SKCM	14	100%	Open	Protected
STAD	18	100%	Open	Protected
THCA	18	100%	Open	Protected
UCEC	22	100%	Open	Protected
PANCANCER	48	87%	Open	Protected

stddata dashboard

The Broad GDAC standardized data packages represent a frozen snapshot of all [TCGA](#) analysis data at a given time:

- **Cast in a form amenable to immediate algorithmic analysis** (no additional data preparation required)
- Which provides a **consistent point of reference** for analysis and [citation by marker papers and users](#) of TCGA data
- Towards a **formal definition** of what constitutes a given tumor dataset
- While **minimizing redundant effort** across centers and groups to download & prepare data for further analysis
- And **enhancing provenance and reproducibility**

2012_08_04 stddata Run

Tables of Ingested Data: [HTML](#) [PNG](#) [TSV](#) Redactions: [Report](#)

ReleaseNotes	# Datasets	% Processed	Download	
BLCA	20	100%	Open	Protected
BRCA	27	100%	Open	Protected
CESC	11	100%	Open	Protected
COADREAD	21	100%	Open	Protected
DLBC	5	100%	Open	Protected
GBM	27	100%	Open	Protected
HNSC	20	100%	Open	Protected
KIRC	27	100%	Open	Protected
KIRP	23	100%	Open	Protected
LAML	11	100%	Open	Protected
LGG	17	100%	Open	Protected
LIHC	17	100%	Open	Protected
LUAD	26	100%	Open	Protected
LUSC	34	100%	Open	Protected
OV	32	100%	Open	Protected
PAAD	6	100%	Open	Protected
PRAD	16	100%	Open	Protected
SKCM	14	100%	Open	Protected
STAD	18	100%	Open	Protected
THCA	18	100%	Open	Protected
UCEC	22	100%	Open	Protected
PANCANCER	48	87%	Open	Protected

Data/Provenance Rigor

Towards solving
BABEL Problem

Launch Point For
Analysis-Ready
TCGA Data



ICGC, too!

stddata dashboard

The Broad GDAC standardized data packages represent a frozen snapshot of all [TCGA](#) analysis data at a given time:

- **Cast in a form amenable to immediate algorithmic analysis** (no additional data preparation required)
- Which provides a **consistent point of reference** for analysis and [citation by marker papers and users](#) of TCGA data
- Towards a **formal definition** of what constitutes a given tumor dataset
- While **minimizing redundant effort** across centers and groups to download & prepare data for further analysis
- And **enhancing provenance and reproducibility**

2012_08_04 stddata Run

Tables of Ingested Data: [HTML](#) [PNG](#) [TSV](#) Redactions: [Report](#)

ReleaseNotes	# Datasets	% Processed	Download	
BLCA	20	100%	Open	Protected
BRCA	27	100%	Open	Protected
CESC	11	100%	Open	Protected
COADREAD	21	100%	Open	Protected
DLBC	5	100%	Open	Protected
GBM	27	100%	Open	Protected
HNSC	20	100%	Open	Protected
KIRC	27	100%	Open	Protected
KIRP	23	100%	Open	Protected
LAML	11	100%	Open	Protected
LGG	17	100%	Open	Protected
LIHC	17	100%	Open	Protected
LUAD	26	100%	Open	Protected
LUSC	34	100%	Open	Protected
OV	32	100%	Open	Protected
PAAD	6	100%	Open	Protected
PRAD	16	100%	Open	Protected
SKCM	14	100%	Open	Protected
STAD	18	100%	Open	Protected
THCA	18	100%	Open	Protected
UCEC	22	100%	Open	Protected
PANCANCER	48	87%	Open	Protected

Data/Provenance Rigor

Towards solving
BABEL Problem

Launch Point For
Analysis-Ready
TCGA Data



ICGC, too!

stddata__2012_11_14 Samples Summary Report

Overview

Introduction

For TCGA data, redaction is the removal of cases from the data prior to publication or release. Redacted cases are generally rare, but cases must be redacted when the TSS/BCR subject link is incorrect ("unknown patient identity"), or in the case of genotype mismatch, completely wrong cancer, or completely wrong organ/tissue. Redaction occurs regardless of a case's analyte characterization or DCC data deposition status.

Rescission is the removal of samples from the list of redactions. This happens if the reason for redaction is eventually cleared up. For clarity, rescinded redactions do not appear in this report.

Summary

There were 60 redactions.

Results

Redactions

Table 1.

Barcode	UUID	Date	Type	Notes
TCGA-BR-4190	282e979d-4ad9-4d42-8ffa-7487a94fa1f3	11/08/2012	STAD	Site found that there was duplicate tissue in their biobank with another ID and different clinical data than that sent to TCGA. Case is being redacted but may be salvaged if the site can reconcile the correct clinical data to the tissue.
TCGA-BR-4194	2c650fe1-48b0-4f88-bc11-04096be48571	11/08/2012	STAD	Site found that there was duplicate tissue in their biobank with another ID and different clinical data than that sent to TCGA. Case is being redacted but may be salvaged if the site can reconcile the correct clinical data to the tissue.
TCGA-BR-4195	7917234c-63be-4320-b7af-535381f99d99	11/08/2012	STAD	Site found that there was duplicate tissue in their biobank with another ID and different clinical data than that sent to TCGA. Case is being redacted but may be salvaged if the site

Rigor, Transparency, Ease

**Comprehensive
report on ingested samples**

From online dashboard

stddata__2012_11_14 Samples Summary Report

Overview

Introduction

For TCGA data, redaction is the removal of cases from the data prior to publication or release. Redacted cases are generally rare, but cases must be redacted when the TSS/BCR subject link is incorrect ("unknown patient identity"), or in the case of genotype mismatch, completely wrong cancer, or completely wrong organ/tissue. Redaction occurs regardless of a case's analyte characterization or DCC data deposition status.

Rescission is the removal of samples from the list of redactions. This happens if the reason for redaction is eventually cleared up. For clarity, rescinded redactions do not appear in this report.

Summary

There were 60 redactions.

Results

Redactions

Table 1.

Barcode	UUID	Date	Type	Notes
TCGA-BR-4190	282e979d-4ad9-4d42-8ffa-7487a94fa1f3	11/08/2012	STAD	Site found that there was duplicate tissue in their biobank with another ID and different clinical data than that sent to TCGA. Case is being redacted but may be salvaged if the site can reconcile the correct clinical data to the tissue.
TCGA-BR-4194	2c650fe1-48b0-4f88-bc11-04096be48571	11/08/2012	STAD	Site found that there was duplicate tissue in their biobank with another ID and different clinical data than that sent to TCGA. Case is being redacted but may be salvaged if the site can reconcile the correct clinical data to the tissue.
TCGA-BR-4195	7917234c-63be-4320-b7af-535381f99d99	11/08/2012	STAD	Site found that there was duplicate tissue in their biobank with another ID and different clinical data than that sent to TCGA. Case is being redacted but may be salvaged if the site

Rigor, Transparency, Ease

**Comprehensive
report on ingested samples**

From online dashboard

Nov 8
STAD
redactions

Clear disposition of every ingested sample, every run

- + Redactions
- + Blacklisted Samples
- Filtered Samples

GET FULL TABLE

Table 3. Click on any filtered samples count to display a table detailing the filtered samples for the associated tumor type.

Tumor Type	Filtered Samples Count
BLCA	40
BRCA	693
CESC	9
COAD	1080
DLBC	18
GBM	930
HNSC	602
KIRC	923
KIRP	209
LIHC	222
LUAD	930
LUSC	726
OV	658
PRAD	548
READ	157
SARC	30
SKCM	35
STAD	274
THCA	242
UCEC	122

- + Redactions
- + Blacklisted Samples
- Filtered Samples

Clear disposition of every ingested sample, every run

GET FULL TABLE

Table 3. Click on any filtered samples count to display a table detailing the filtered samples for the associated tumor type.

Tumor Type	Filtered Samples Count
BLCA	40
BRCA	693
CESC	9
COAD	1080
DLBC	18
GBM	930
HNSC	602
KIRC	923
KIRP	209
LIHC	222
LUAD	930
LUSC	726
OV	658
PRAD	548
READ	157
SARC	30
SKCM	35
STAD	274
THCA	242
UCEC	122

Downloadable as TSV

Clear disposition of every ingested sample, every run

- + Redactions
- + Blacklisted Samples
- Filtered Samples

GET FULL TABLE

Table 3. Click on any filtered samples count to display a table detailing the filtered samples for the associated tumor type.

Tumor Type	Filtered Samples Count
BLCA	40
BRCA	693
CESC	9
COAD	1080
DLBC	18
GBM	930
HNSC	602
KIRC	923
KIRP	209
LIHC	222
LUAD	930
LUSC	726
OV	658
PRAD	548
READ	157
SARC	30
SKCM	35
STAD	274
THCA	242
UCEC	122

Downloadable as TSV

Or view heatmap figure

Sample Heatmaps

BLCA

Figure 1. This figure depicts the distribution of available data on a per participant basis.

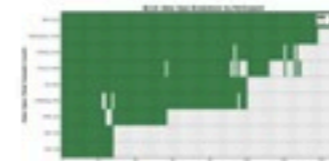

GET HIGH-RES IMAGE

BRCA

Figure 2. This figure depicts the distribution of available data on a per participant basis.

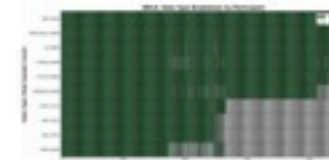

GET HIGH-RES IMAGE

CESC

analysis dashboard

2012_07_25 analyses Run

Tables of Ingested Data: [HTML](#) [PNG](#) [TSV](#)

AnalysisReport	# Pipelines	% Successful	Download
BLCA	18	100%	Open Protected
BRCA	29	100%	Open Protected
CESC	12	100%	Open Protected
COADREAD	29	100%	Open Protected
GBM	28	100%	Open Protected
HNSC	15	100%	Open Protected
KIRC	29	100%	Open Protected
LAML	13	100%	Open Protected
LGG	22	100%	Open Protected
LIHC	10	100%	Open Protected
OV	35	100%	Open Protected
PRAD	14	100%	Open Protected
SKCM	12	100%	Open Protected
THCA	15	100%	Open Protected
UCEC	29	100%	Open Protected
KIRP	22	96%	Open Protected
LUAD	23	96%	Open Protected
LUSC	20	95%	Open Protected
STAD	16	94%	Open Protected
PAAD	4	80%	Open Protected
PANCANCER	8	41%	Open Protected

analysis dashboard

2012_07_25 analyses Run

Tables of Ingested Data: [HTML](#) [PNG](#) [TSV](#)

AnalysisReport	# Pipelines	% Successful	Download
BLCA	18	100%	Open Protected
BRCA	29	100%	Open Protected
CESC	12	100%	Open Protected
COADREAD	29	100%	Open Protected
GBM	28	100%	Open Protected
HNSC	15	100%	Open Protected
KIRC	29	100%	Open Protected
LAML	13	100%	Open Protected
LGG	22	100%	Open Protected
LIHC	10	100%	Open Protected
OV	35	100%	Open Protected
PRAD	14	100%	Open Protected
SKCM	12	100%	Open Protected
THCA	15	100%	Open Protected
UCEC	29	100%	Open Protected
KIRP	22	96%	Open Protected
LUAD	23	96%	Open Protected
LUSC	20	95%	Open Protected
STAD	16	94%	Open Protected
PAAD	4	80%	Open Protected
PANCANCER	8	41%	Open Protected

Tumor	BCR	Clinical	CN	LowP	Methylation	mRNA	mRNAseq	miR	miRseq	RPPA	MAF
BLCA	126	67	58	0	78	0	56	0	88	0	28
BRCA	899	862	833	0	858	529	777	0	809	408	507
CESC	122	31	68	0	0	0	0	0	42	0	36
COADREAD	592	591	575	76	584	224	83	0	255	399	224
DLBC	27	0	0	0	0	0	0	0	0	0	0
GBM	596									214	276
HNSC	312									0	0
KICH	65									0	0
KIRC	502									454	403
KIRP	135									0	0
LAML	202									0	199
LOG	181									0	0
LIHC	99									0	0
LNNH	2									0	0
LUAD	439									0	229
LUSC	360									0	178
OV	592	580	564	0	551	568	297	564	454	412	316
PAAD	48	0	14	0	30	0	0	0	0	0	0
PRAD	174	127	300	0	153	0	53	0	81	0	83
SARC	29	0	0	0	0	0	0	0	0	0	0
SKCM	253	129	219	0	240	0	212	0	240	0	0
STAD	226	159	132	0	133	0	57	0	127	0	133
THCA	353	188	228	0	230	0	158	0	138	0	0
UCEC	512	451	430	0	451	54	266	0	367	200	248
PANCANCER	6846	5633	5386	76	5465	2218	3460	1055	3976	2087	2860

Sample Counts
(tabular/programmatic too)

analysis dashboard

2012_07_25 analyses Run

Tables of Ingested Data: [HTML](#) [PNG](#) [TSV](#)

AnalysisReport	# Pipelines	% Successful	Download
BLCA	18	100%	Open Protected
BRCA	29	100%	Open Protected
CESC	12	100%	Open Protected
COADREAD	29	100%	Open Protected
GBM	28	100%	Open Protected
HNSC	15	100%	Open Protected
KIRC	29	100%	Open Protected
LAML	13	100%	Open Protected
LGG	22	100%	Open Protected
LIHC	10	100%	Open Protected
OV	35	100%	Open Protected
PRAD	14	100%	Open Protected
SKCM	12	100%	Open Protected
THCA	15	100%	Open Protected
UCEC	29	100%	Open Protected
KIRP	22	96%	Open Protected
LUAD	23	96%	Open Protected
LUSC	20	95%	Open Protected
STAD	16	94%	Open Protected
PAAD	4	80%	Open Protected
PANCANCER	8	41%	Open Protected

Tumor	BCR	Clinical	CN	LowP	Methylation	mRNA	mRNAseq	miR	miRseq	RPPA	MAF
BLCA	126	67	58	0	78	0	56	0	88	0	28
BRCA	899	862	833	0	858	529	777	0	809	408	507
CESC	122	31	68	0	0	0	0	0	42	0	36
COADREAD	592	591	575	76	584	224	83	0	255	399	224
DLBC	27	0	0	0	0	0	0	0	0	0	0
GBM	596									214	276
HNSC	312									0	0
KICH	65									0	0
KIRC	502									454	403
KIRP	135									0	0
LAML	202									0	199
LOG	181									0	0
LIHC	99									0	0
LNNH	2									0	0
LUAD	439									0	229
LUSC	360									0	178
OV	592	580	564	0	551	568	297	564	454	412	316
PAAD	48	0	14	0	30	0	0	0	0	0	0
PRAD	174	127	100	0	153	0	53	0	81	0	83
SARC	29	0	0	0	0	0	0	0	0	0	0
SKCM	253	129	219	0	240	0	212	0	240	0	0
STAD	226	159	132	0	133	0	57	0	127	0	133
THCA	353	188	228	0	230	0	158	0	138	0	0
UCEC	512	451	430	0	451	54	266	0	367	200	248
PANCANCER	6846	5633	5386	76	5465	2218	3460	1055	3976	2087	2860

Sample Counts
(tabular/programmatic too)

Pipeline	NotRunnable	Runnable	InProcess	Successful	Unsuccessful
1 Aggregate_Clusters	0	0	0	1	0
2 CopyNumber_GeneBySample	0	0	0	1	0
3 CopyNumber_Gistic2	0	0	0	1	0
4 Correlate_Clinical_vs_CopyNumber_Arm	0	0	0	1	0
5 Correlate_Clinical_vs_CopyNumber_Focal	0	0	0	1	0
6 Correlate_Clinical_vs_miR	0	0	0	1	0
7 Correlate_Clinical_vs_Molecular_Signatures	0	0	0	1	0
8 Correlate_Clinical_vs_mRNA	0	0	0	1	0
9 Correlate_Clinical_vs_Mutation	0	0	0	1	0
10 Correlate_CopyNumber_vs_miR	0	0	0	1	0
11 Correlate_CopyNumber_vs_mRNA	0	0	0	1	0
12 Correlate_CopyNumber_vs_mRNAseq	0	0	0	1	0
13 Correlate_Methylation_vs_mRNA	0	0	0	1	0
14 Methylation_Clustering_CNMF	0	0	0	1	0
15 Methylation_Preprocess	0	0	0	1	0
16 miRseq_Clustering_CNMF	0	0	0	1	0
17 miRseq_Clustering_Consensus	0	0	0	1	0
18 miRseq_Preprocess	0	0	0	1	0
19 miR_Clustering_CNMF	0	0	0	1	0
20 miR_Clustering_Consensus	0	0	0	1	0
21 miR_FindDirectTargets	0	0	0	1	0
22 miR_Preprocess	0	0	0	1	0
23 mRNAseq_Clustering_CNMF	0	0	0	1	0
24 mRNAseq_Clustering_Consensus	0	0	0	1	0
25 mRNAseq_Preprocess	0	0	0	1	0
26 mRNA_Clustering_CNMF	0	0	0	1	0
27 mRNA_Clustering_Consensus	0	0	0	1	0
28 mRNA_Preprocess_Median	0	0	0	1	0
29 Mutation_Assessor	0	0	0	1	0
30 Mutation_Significance	0	0	0	1	0
31 Pathway_FindEnrichedGenes	0	0	0	1	0
32 Pathway_Paradigm_Expression	0	0	0	1	0
33 Pathway_Paradigm_Expression_CopyNumber	0	0	0	1	0
34 RPPA_Clustering_CNMF	0	0	0	1	0
35 RPPA_Clustering_Consensus	0	0	0	1	0

Analyses
Performed

Linked to Biologist-Friendly Reports

2012_07_25 analyses Run

Tables of Ingested Data: [HTML](#) [PNG](#) [TSV](#) Redactions: [Report](#)

AnalysisReport	# Pipelines	% Successful	Download
BLCA	18	100%	Open Protected
BRCA	29	100%	Open Protected
CESC	12	100%	Open Protected
COADREAD	29	100%	Open Protected
GBM	28	100%	Open Protected
HNSC	15	100%	Open Protected
KIRC	29	100%	Open Protected
LAML	13	100%	Open Protected
LGG	22	100%	Open Protected
LIHC	10	100%	Open Protected
OV	35	100%	Open Protected
PRAD	14	100%	Open Protected
SKCM	12	100%	Open Protected
THCA	15	100%	Open Protected
UCEC	29	100%	Open Protected
KIRP	22	96%	Open Protected
LUAD	23	96%	Open Protected
LUSC	20	95%	Open Protected
STAD	16	94%	Open Protected
PAAD	4	80%	Open Protected
PANCANCER	8	41%	Open Protected

View: [Analysis reports](#) [Release notes](#) [FAQ](#) Download: [firehose_get](#)

Linked to Biologist-Friendly Reports

2012_07_25 analyses Run

Tables of Ingested Data: [HTML](#) [PNG](#) [TSV](#) Redactions: [Report](#)

AnalysisReport	# Pipelines	% Successful	Download
BLCA	18	100%	Open Protected
BRCA	29	100%	Open Protected
CESC	12	100%	Open Protected
COADREAD	29	100%	Open Protected
GBM	28	100%	Open Protected
HNSC	15	100%	Open Protected
KIRC	29	100%	Open Protected
LAML	13	100%	Open Protected
LGG	22	100%	Open Protected
LIHC	18	100%	Open Protected
OV	35	100%	Open Protected
PRAD	14	100%	Open Protected
SKCM	12	100%	Open Protected
THCA	15	100%	Open Protected
UCEC	29	100%	Open Protected
KIRP	22	96%	Open Protected
LUAD	23	96%	Open Protected
LUSC	20	95%	Open Protected
STAD	16	94%	Open Protected
PAAD	4	80%	Open Protected
PANCANCER	8	41%	Open Protected

Analysis Overview for Ovarian Serous Cystadenocarcinoma

Maintained by [TCGA GDAC Team](#) (Broad Institute/Dana-Farber Cancer Institute/Harvard Medical School)

- Overview
- + Introduction
- Summary

Note: These results are offered to the community as an additional reference point, enabling a wide range of cancer biologists, clinical investigators, and genome and computational scientists to easily incorporate TCGA into the backdrop of ongoing research. While every effort is made to ensure that Firehose input data and algorithms are of the highest possible quality, these analyses have not been reviewed by domain experts.

- Results
 - *Sequence and Copy Number Analyses*
 - **Copy number analysis (GISTIC2)**
[View Report](#) | There were 547 tumor samples used in this analysis: 29 significant arm-level results, 35 significant focal amplifications, and 46 significant focal deletions were found.
 - **Mutation Analysis (MutSig)**
[View Report](#) | Significantly mutated genes ($q \leq 0.1$): 24
 - *Clustering Analyses*
 - **Clustering of mRNA expression: consensus NMF**
[View Report](#) | The most robust consensus NMF clustering of 565 samples using the 1500 most variable genes was identified for $k = 3$ clusters. We computed the clustering for $k = 2$ to $k = 8$ and used the cophenetic correlation coefficient to determine the best solution.
 - **Clustering of mRNA expression: consensus hierarchical**
[View Report](#) | The 1500 most variable genes were selected. Consensus average linkage hierarchical clustering of 565 samples and 1500 genes identified 3 subtypes with the stability of the clustering increasing for $k = 2$ to $k = 8$ and the average silhouette width calculation for selecting the robust clusters.
 - **Clustering of Methylation: consensus NMF**
[View Report](#) | The 1229 most variable methylated genes were selected based on variation. The variation cutoff are set for each tumor type empirically by fitting a bimodal distribution. For genes with multiple methylation probes, we chose the most variable one to represent the gene. Consensus NMF clustering of 551 samples and 1229 genes identified 6 subtypes with the stability of the clustering increasing for $k = 2$ to $k = 8$ and the average silhouette width calculation for selecting the robust clusters.
 - **Clustering of miR expression: consensus NMF**
[View Report](#) | We filtered the data to 150 most variable miRs. Consensus NMF clustering of 564 samples and 150 miRs identified 3 subtypes with the stability of the clustering increasing for $k = 2$ to $k = 8$ and the average silhouette width calculation for selecting the robust clusters.

View: [Analysis reports](#) [Release notes](#) [FAQ](#) Download: [firehose_get](#)

Organized like a paper

- Overview (“Abstract”)
- Results
- Methods & Data

With Browser Convenience

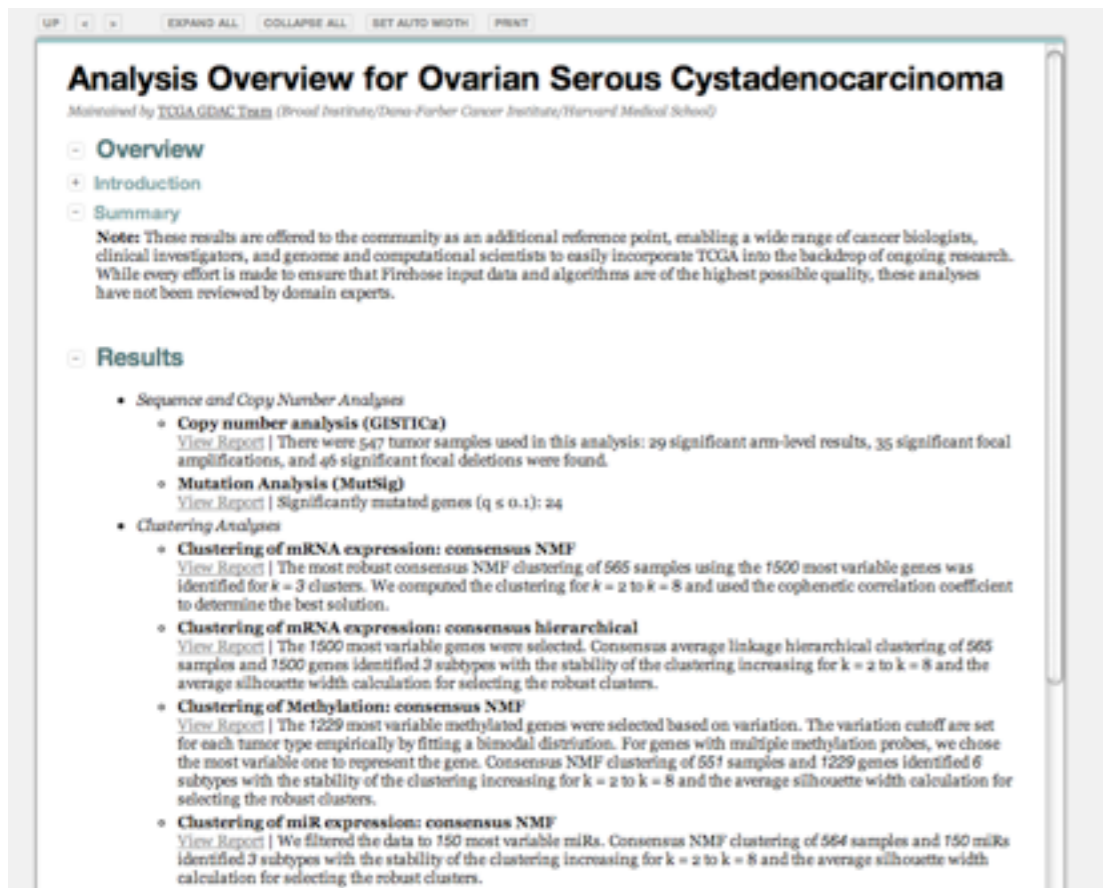

UP < > EXPAND ALL COLLAPSE ALL SET AUTO WIDTH PRINT

Analysis Overview for Ovarian Serous Cystadenocarcinoma

Maintained by TCGA, GDC, Team (Broad Institute/Dana-Farber Cancer Institute/Harvard Medical School)

- Overview
 - Introduction
 - Summary

Note: These results are offered to the community as an additional reference point, enabling a wide range of cancer biologists, clinical investigators, and genome and computational scientists to easily incorporate TCGA into the backdrop of ongoing research. While every effort is made to ensure that Firehose input data and algorithms are of the highest possible quality, these analyses have not been reviewed by domain experts.
- Results
 - Sequence and Copy Number Analyses
 - Copy number analysis (GISTIC)**
[View Report](#) | There were 547 tumor samples used in this analysis: 29 significant arm-level results, 35 significant focal amplifications, and 46 significant focal deletions were found.
 - Mutation Analysis (MutSig)**
[View Report](#) | Significantly mutated genes ($q \leq 0.1$): 24
 - Clustering Analyses
 - Clustering of mRNA expression: consensus NMF**
[View Report](#) | The most robust consensus NMF clustering of 565 samples using the 1500 most variable genes was identified for $k = 3$ clusters. We computed the clustering for $k = 2$ to $k = 8$ and used the cophenetic correlation coefficient to determine the best solution.
 - Clustering of mRNA expression: consensus hierarchical**
[View Report](#) | The 1500 most variable genes were selected. Consensus average linkage hierarchical clustering of 565 samples and 1500 genes identified 3 subtypes with the stability of the clustering increasing for $k = 2$ to $k = 8$ and the average silhouette width calculation for selecting the robust clusters.
 - Clustering of Methylation: consensus NMF**
[View Report](#) | The 1229 most variable methylated genes were selected based on variation. The variation cutoff are set for each tumor type empirically by fitting a bimodal distribution. For genes with multiple methylation probes, we chose the most variable one to represent the gene. Consensus NMF clustering of 557 samples and 1229 genes identified 6 subtypes with the stability of the clustering increasing for $k = 2$ to $k = 8$ and the average silhouette width calculation for selecting the robust clusters.
 - Clustering of miR expression: consensus NMF**
[View Report](#) | We filtered the data to 150 most variable miRs. Consensus NMF clustering of 564 samples and 150 miRs identified 3 subtypes with the stability of the clustering increasing for $k = 2$ to $k = 8$ and the average silhouette width calculation for selecting the robust clusters.

Organized like a paper

- Overview (“Abstract”)
- Results
- Methods & Data

With Browser Convenience

Analysis Overview for Ovarian Serous Cystadenocarcinoma
Maintained by TCGA, GDHC Team (Broad Institute/Dana-Farber Cancer Institute/Harvard Medical School)

- Overview
- Introduction
- Summary
- Note: These results are offered to the community as an additional reference point, enabling a wide range of cancer biologists, clinical investigators, and genome and computational scientists to easily incorporate TCGA into the backdrop of ongoing research. While every effort is made to ensure that Firehose input data and algorithms are of the highest possible quality, these analyses have not been reviewed by domain experts.
- Results
 - Sequence and Copy Number Analyses
 - Copy number analysis (GISTIC2)
View Report | There were 547 tumor samples used in this analysis: 29 significant arm-level results, 35 significant focal amplifications, and 46 significant focal deletions were found.
 - Mutation Analysis (MutSig)
View Report | Significantly mutated genes ($q \leq 0.1$): 24
 - Clustering Analyses
 - Clustering of mRNA expression: consensus NMF
View Report | The most robust consensus NMF clustering of 565 samples using the 1500 most variable genes was identified for $k = 3$ clusters. We computed the clustering for $k = 2$ to $k = 8$ and used the cophenetic correlation coefficient to determine the best solution.
 - Clustering of mRNA expression: consensus hierarchical
View Report | The 1500 most variable genes were selected. Consensus average linkage hierarchical clustering of 565 samples and 1500 genes identified 3 subtypes with the stability of the clustering increasing for $k = 2$ to $k = 8$ and the average silhouette width calculation for selecting the robust clusters.
 - Clustering of Methylation: consensus NMF
View Report | The 1229 most variable methylated genes were selected based on variation. The variation cutoff are set for each tumor type empirically by fitting a bimodal distribution. For genes with multiple methylation probes, we chose the most variable one to represent the gene. Consensus NMF clustering of 557 samples and 1229 genes identified 6 subtypes with the stability of the clustering increasing for $k = 2$ to $k = 8$ and the average silhouette width calculation for selecting the robust clusters.
 - Clustering of miR expression: consensus NMF
View Report | We filtered the data to 150 most variable miRs. Consensus NMF clustering of 564 samples and 150 miRs identified 3 subtypes with the stability of the clustering increasing for $k = 2$ to $k = 8$ and the average silhouette width calculation for selecting the robust clusters.

Ovarian Serous Cystadenocarcinoma: Copy number analysis (GISTIC2)

Maintained by Dan DiCara (Broad Institute)

Overview

Introduction

Summary

There were 547 tumor samples used in this analysis: 29 significant arm-level results, 35 significant focal amplifications, and 46 significant focal deletions were found.

Results

Focal results

Figure 1. Genomic positions of amplified regions: the X-axis represents the normalized amplification signals (top) and significance by Q value (bottom). The green line represents the significance cutoff at Q value=0.25.



Table 1. Amplifications Table - 35 significant amplifications found. Click the link in the last column to view a comprehensive list of candidate genes. If no genes were identified within the peak, the nearest gene appears in brackets.

Cytoband	Q value	Residual Q value	Wide Peak Boundaries	# Genes in Wide Peak
8q24.21	2.645e-77	2.645e-77	chr8:128574848-129810279	5
19q12	1.8147e-87	8.4949e-76	chr19:34947990-35023082	1
3q26.2	1.0722e-60	1.0722e-60	chr3:170903217-170923258	0 [MECOM]

Ovarian Serous Cystadenocarcinoma: Clustering of mRNA expression: consensus NMF

Maintained by Robert Zapko (Broad Institute)

Overview

Introduction

Summary

The most robust consensus NMF clustering of 565 samples using the 1500 most variable genes was identified for $k = 3$ clusters. We computed the clustering for $k = 2$ to $k = 8$ and used the cophenetic correlation coefficient to determine the best solution.

Results

Gene expression patterns of molecular subtypes

Consensus and correlation matrix

Figure 2. The consensus matrix after clustering shows 3 clusters with limited overlap between clusters.

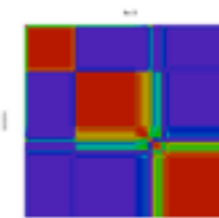

Organized like a paper

- Overview (“Abstract”)
- Results
- Methods & Data

With Browser Convenience

Analysis Overview for Ovarian Serous Cystadenocarcinoma
Maintained by TCGA, GDHC Team (Broad Institute/Dana-Farber Cancer Institute/Harvard Medical School)

- Overview
- Introduction
- Summary
- Note: These results are offered to the community as an additional reference point, enabling a wide range of cancer biologists, clinical investigators, and genome and computational scientists to easily incorporate TCGA into the backdrop of ongoing research. While every effort is made to ensure that Firehose input data and algorithms are of the highest possible quality, these analyses have not been reviewed by domain experts.
- Results
 - Sequence and Copy Number Analyses
 - Copy number analysis (GISTIC2)**
View Report | There were 547 tumor samples used in this analysis: 29 significant arm-level results, 35 significant focal amplifications, and 46 significant focal deletions were found.
 - Mutation Analysis (MutSig)**
View Report | Significantly mutated genes ($q \leq 0.1$): 24
 - Clustering Analyses
 - Clustering of mRNA expression: consensus NMF**
View Report | The most robust consensus NMF clustering of 565 samples using the 1500 most variable genes was identified for $k = 3$ clusters. We computed the clustering for $k = 2$ to $k = 8$ and used the cophenetic correlation coefficient to determine the best solution.
 - Clustering of mRNA expression: consensus hierarchical**
View Report | The 1500 most variable genes were selected. Consensus average linkage hierarchical clustering of 565 samples and 1500 genes identified 3 subtypes with the stability of the clustering increasing for $k = 2$ to $k = 8$ and the average silhouette width calculation for selecting the robust clusters.
 - Clustering of Methylation: consensus NMF**
View Report | The 1229 most variable methylated genes were selected based on variation. The variation cutoff are set for each tumor type empirically by fitting a bimodal distribution. For genes with multiple methylation probes, we chose the most variable one to represent the gene. Consensus NMF clustering of 557 samples and 1229 genes identified 6 subtypes with the stability of the clustering increasing for $k = 2$ to $k = 8$ and the average silhouette width calculation for selecting the robust clusters.
 - Clustering of miR expression: consensus NMF**
View Report | We filtered the data to 150 most variable miRs. Consensus NMF clustering of 564 samples and 150 miRs identified 3 subtypes with the stability of the clustering increasing for $k = 2$ to $k = 8$ and the average silhouette width calculation for selecting the robust clusters.

Ovarian Serous Cystadenocarcinoma: Copy number analysis (GISTIC2)

Maintained by Dan DiCara (Broad Institute)

Overview

Introduction

Summary

There were 547 tumor samples used in this analysis: 29 significant arm-level results, 35 significant focal amplifications, and 46 significant focal deletions were found.

Results

Focal results

Figure 1. Genomic positions of amplified regions: the X-axis represents the normalized amplification signals (top) and significance by Q value (bottom). The green line represents the significance cutoff at Q value=0.25.



Table 1. Amplifications Table - 35 significant amplifications found. Click the link in the last column to view a comprehensive list of candidate genes. If no genes were identified within the peak, the nearest gene appears in brackets.

Cytoband	Q value	Residual Q value	Wide Peak Boundaries	# Genes in Wide Peak
8q24.21	2.645e-77	2.645e-77	chr8:128574848-129810279	5
19q12	1.8147e-87	8.4949e-76	chr19:34947990-35023082	1
3q26.2	1.0722e-60	1.0722e-60	chr3:170903217-170923258	0 [MECOM]

Ovarian Serous Cystadenocarcinoma: Clustering of mRNA expression: consensus NMF

Maintained by Robert Zapko (Broad Institute)

Overview

Introduction

Summary

The most robust consensus NMF clustering of 565 samples using the 1500 most variable genes was identified for $k = 3$ clusters. We computed the clustering for $k = 2$ to $k = 8$ and used the cophenetic correlation coefficient to determine the best solution.

Results

Gene expression patterns of molecular subtypes

Consensus and correlation matrix

Figure 2. The consensus matrix after clustering shows 3 clusters with limited overlap between clusters.

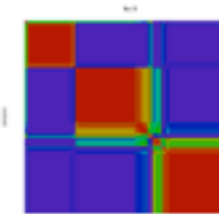

Completely Open: no passwords
Linked to downloadable data

- Summary

There were 558 tumor samples used in this analysis: 29 significant arm-level results, 34 significant focal amplifications, and 47 significant focal deletions were found.

- Results ●

+ Focal results ●

- Arm-level results ●

GET FULL TABLE

Table 3. Arm-level significance table - 29 significant results found.

Arm	# Genes	Amp Frequency	Amp Z score	Amp Q value	Del Frequency	Del Z score	Del Q value
1p	2121	0.21	0.131	1	0.10	-5.72	1
1q	1955	0.34	6.49	4.26e-10	0.09	-6.29	1
2p	924	0.27	-2.25	1	0.07	-10.7	1
2q	1556	0.22	-2.32	1	0.07	-9.07	1
3p	1062	0.23	-3.6	1	0.20	-4.8	1
3q	1139	0.49	9.71	0			
4p	489	0.14	-7.22	1			
4q	1049	0.07	-7.69	1			

- Standard visual format for ALL pipelines

- Summary

There were 558 tumor samples used in this analysis: 29 significant arm-level results, 34 significant focal amplifications, and 47 significant focal deletions were found.

- Results ●

+ Focal results ●

- Arm-level results ●

GET FULL TABLE

Table 3. Arm-level significance table - 29 significant results found.

Arm	# Genes	Amp Frequency	Amp Z score	Amp Q value	Del Frequency	Del Z score	Del Q value
1p	2121	0.21	0.131	1	0.10	-5.72	1
1q	1955	0.34	6.49	4.26e-10	0.09	-6.29	1
2p	924	0.27	-2.25	1	0.07	-10.7	1
2q	1556	0.22	-2.32	1	0.07	-9.07	1
3p	1062	0.23	-3.6	1	0.20	-4.8	1
3q	1139	0.49	9.71	0			
4p	489	0.14	-7.22	1			
4q	1049	0.07	-7.69	1			

- Standard visual format for ALL pipelines
- As little as 3-5 simple R calls
- Thoughtfully Scoped:
 - drill from overview to details
 - Significant results “bubble up”

- Summary

There were 558 tumor samples used in this analysis: 29 significant arm-level results, 34 significant focal amplifications, and 47 significant focal deletions were found.

- Results ●

+ Focal results ●

- Arm-level results ●

GET FULL TABLE

Table 3. Arm-level significance table - 29 significant results found.

Arm	# Genes	Amp Frequency	Amp Z score	Amp Q value	Del Frequency	Del Z score	Del Q value
1p	2121	0.21	0.131	1	0.10	-5.72	1
1q	1955	0.34	6.49	4.26e-10	0.09	-6.29	1
2p	924	0.27	-2.25	1	0.07	-10.7	1
2q	1556	0.22	-2.32	1	0.07	-9.07	1
3p	1062	0.23	-3.6	1	0.20	-4.8	1
3q	1139	0.49	9.71	0			
4p	489	0.14	-7.22	1			
4q	1049	0.07	-7.69	1			

- Standard visual format for ALL pipelines
- As little as 3-5 simple R calls
- Thoughtfully Scoped:
 - drill from overview to details
 - Significant results “bubble up”
- **don't miss needle in haystack**

- Summary

There were 558 tumor samples used in this analysis: 29 significant arm-level results, 34 significant focal amplifications, and 47 significant focal deletions were found.

- Results ●

+ Focal results ●

- Arm-level results ●

GET FULL TABLE

RIGOR: nothing thrown away

Table 3. Arm-level significance table - 29 significant results found.

Arm	# Genes	Amp Frequency	Amp Z score	Amp Q value	Del Frequency	Del Z score	Del Q value
1p	2121	0.21	0.131	1	0.10	-5.72	1
1q	1955	0.34	6.49	4.26e-10	0.09	-6.29	1
2p	924	0.27	-2.25	1	0.07	-10.7	1
2q	1556	0.22	-2.32	1	0.07	-9.07	1
3p	1062	0.23	-3.6	1	0.20	-4.8	1
3q	1139	0.49	9.71	0			
4p	489	0.14	-7.22	1			
4q	1049	0.07	-7.69	1			

- Standard visual format for ALL pipelines
- As little as 3-5 simple R calls
- Thoughtfully Scoped:
 - drill from overview to details
 - Significant results “bubble up”
 - **don't miss needle in haystack**

Firehose Reports | At-a-Glance



→ Reports are compatible with Firefox 4+, Chrome 12+, Safari 5+, Opera 11+ and Internet Explorer 9+.

Navigation: UP, DOWN, LEFT, RIGHT arrows to navigate between reports or to the overview page.

Expand/Collapse: EXPAND ALL, COLLAPSE ALL buttons to manage report sections.

Width: SET AUTO WIDTH button to fit the report to the browser window.

Print: PRINT REPORT button to load a printable version.

Feedback: REPORT A PROBLEM button to report issues.

Interactivity: Clicking on figures (e.g., genomic plots) enlarges them; clicking again scales them down.

Significance: Red markers in the Results section indicate statistically significant results.

Table Data:

Cytoband	Q value	Residual Q value	Wide Peak Boundaries	# Genes in Wide Peak
7p11.2	0	0	chr7:54954372-54968011	0 [EGFR]
12q14.1	5.1922e-05	6.202e-113	chr12:56411663-56442647	5
4q12	6.7649e-85	6.7649e-85	chr4:54727006-54861623	1
10q25.3	1.5248e-57	1.7421e-57	chr10:202664385-202815140	2
12q15	3.8163e-70	4.0392e-31	chr12:67457108-67551544	2
3q26.33	4.5642e-09	4.5642e-09	chr3:182584087-183044402	2
7q31.2	9.9818e-09	1.7005e-08	chr7:11650324-116267511	1
12p13.32	2.4873e-08	2.4873e-08	chr12:3839133-4302336	3
10q44	2.0116e-07	4.0275e-07	chr10:241495233-242804011	6
7q21.2	1.2098e-06	2.7782e-06	chr7:31966270-92368284	5
11p15.5	1.7964e-05	1.7964e-05	chr11:13735235-14250524	2
2p24.3	4.5245e-05	4.5245e-05	chr2:15933392-16304271	2
13q34	0.03487	0.03487	chr13:108563148-109682658	3
19q12	0.069145	0.069145	chr19:34867390-35007574	2

Supplementary Information: Underlined results (e.g., 5, 1) have associated supplementary information. Clicking opens a panel with details like "Genes in Wide Peak" (CDK4, CYP27B1, TSPAN31, MARCKS9, AGAP2).

Download: Download Results button to get analysis results, auxiliary data, and MAGE-TAB files.

Again, aimed at solid design & engineering

Nozzle package downloadable as open source

Used in multiple external projects

Programmatic, Too

```
firehose_get : retrieve open-access results of Broad Institute TCGA GDAC runs
Version: 0.3.3 (Author: Michael S. Noble)

Usage: firehose_get [flags] RunType Date [tumor_type, ... ]
```

firehose_get

```
BLCA BRCA CESC COADREAD DLBC GBM HNSC KIRC KIRP LAML LGG LIHC
LNNH LUAD LUSC OV PAAD PRAD SKCM STAD THCA UCEC PANCANCER
```

- Download all or parts
- Of data or analyses runs
- **Open access : no password**
- Select by run type & date
- Subselect by tumor type
- Or analyses type / name
- See what runs we did
- Or what tasks in each run

10K download from gdac.broadinstitute.org

```
% firehose_get -runs
```

Run	At_DCC	Available_From_Broad_GDAC
...		
analyses__2012_04_25	yes	yes
analyses__2012_05_25	yes	yes
analyses__2012_06_23	yes	yes
analyses__2012_07_25	no	yes

```
% firehose_get -tasks analyses 2012_07_25
```

```
...  
CopyNumber_Gistic2  
Correlate_Clinical_vs_CopyNumber_Arm  
Correlate_Clinical_vs_Molecular_Signatures  
Correlate_Clinical_vs_Mutation  
...  
Correlate_CopyNumber_vs_miR  
Correlate_CopyNumber_vs_mRNAseq  
Correlate_Methylation_vs_mRNA  
...  
Methylation_Clustering_CNMF  
miRseq_Clustering_CNMF  
miRseq_Clustering_Consensus  
miR_Clustering_CNMF  
...  
mRNAseq_Clustering_CNMF  
...  
mRNAseq_Clustering_Consensus  
mRNAseq_Preprocess  
Mutation_Significance  
...  
Pathway_FindEnrichedGenes  
Pathway_Paradigm_Expression  
...  
RPPA_Clustering_CNMF  
...
```

These analyses are what is described by the reports on our GDAC dashboards

THANK YOU!

<http://gdac.broadinstitute.org>

gdac@broadinstitute.org